

Outil	Chariot établi			L'atelier paysan	
Date	30/10/2017	Version	2.1		page n° 1 / 7
Pièce	Vue générale		Qté		1

Fournitures nécessaires

N°	Désignation	Longueur	Qté
A1	tube carré 35 x 2	1010	2
A2	tube carré 35 x 2	530	2
A3	tube carré 40 x 2	100	4
A4	tôle 1010*600*3mm		1
B1	tube carré 35 x 2	470	4
B2	tube carré 35 x 2	910	4
B3	Fer plat 40 x 5	40	4
fixe diam 125	Roue caoutchouc fixe Ø125		2
oscill diam 125	Roue oscillante Ø125		2
Ecrou	Ecrou M10 brut		4
Vis Hexagonale	vis hexagonale M10 x 30		4
C1	étiré rond Ø10	50	4

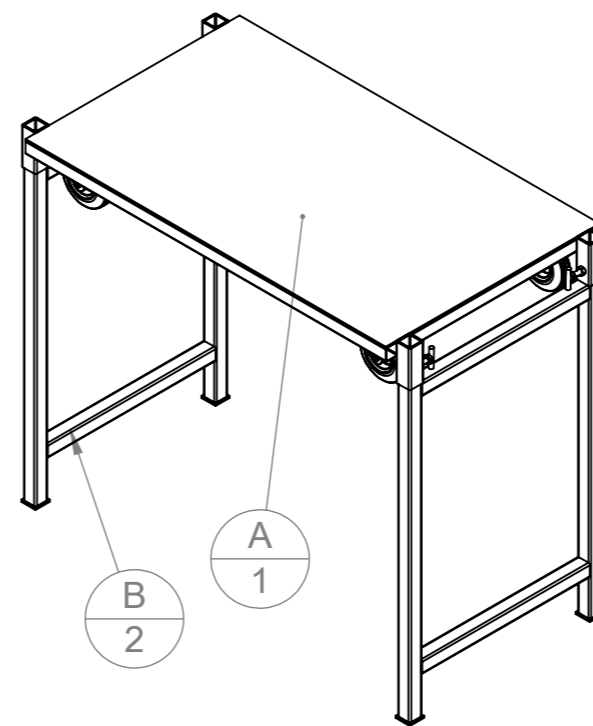

Etabli

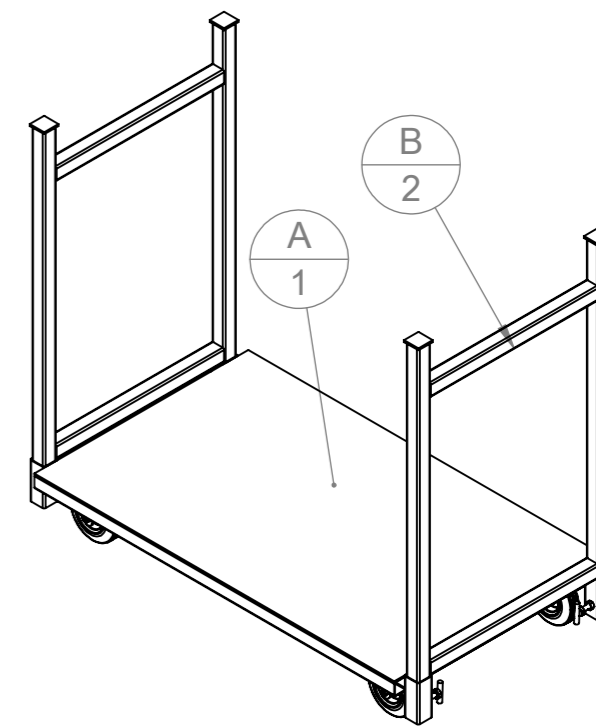

Chariot

Désignation	Qté
A - Base	1
B - Pied	2

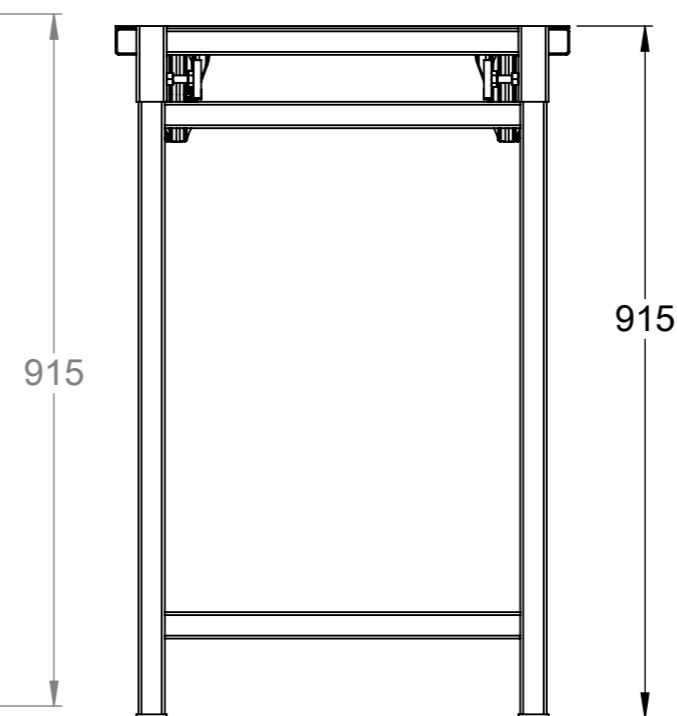
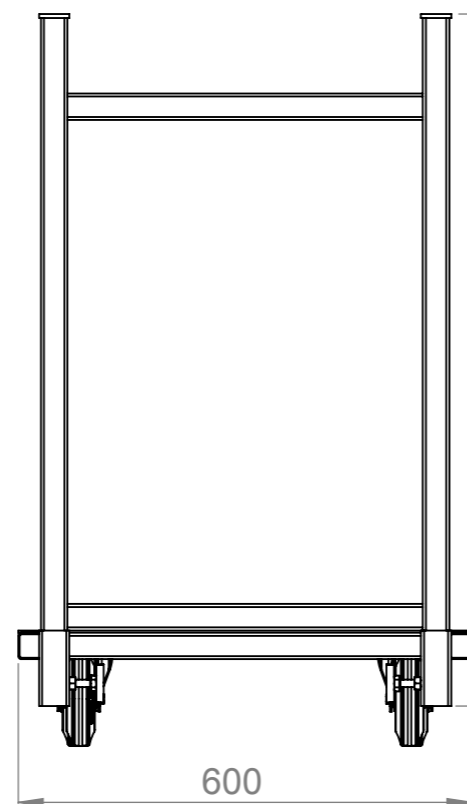
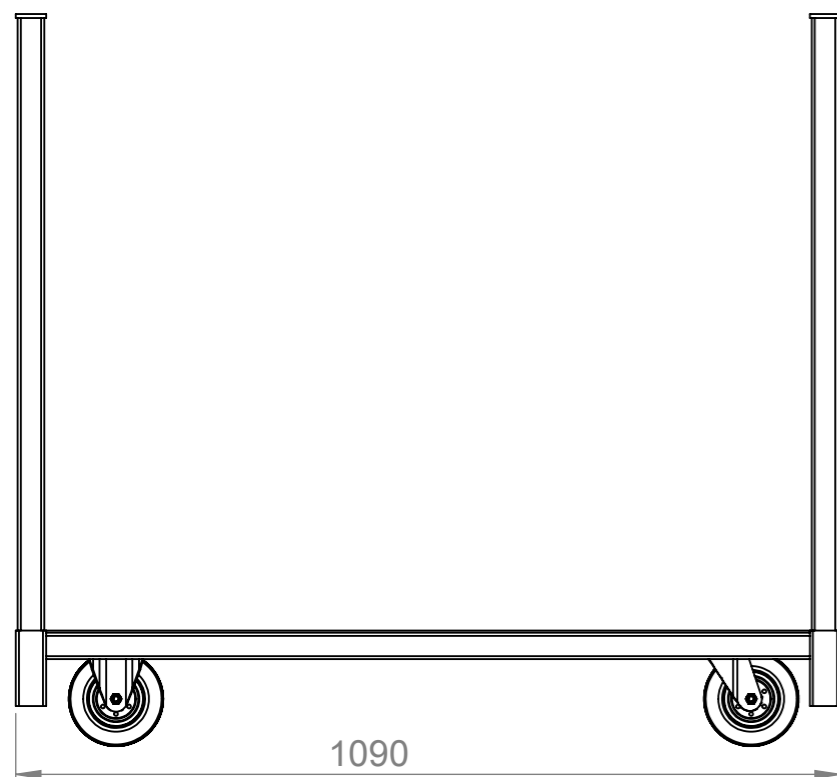

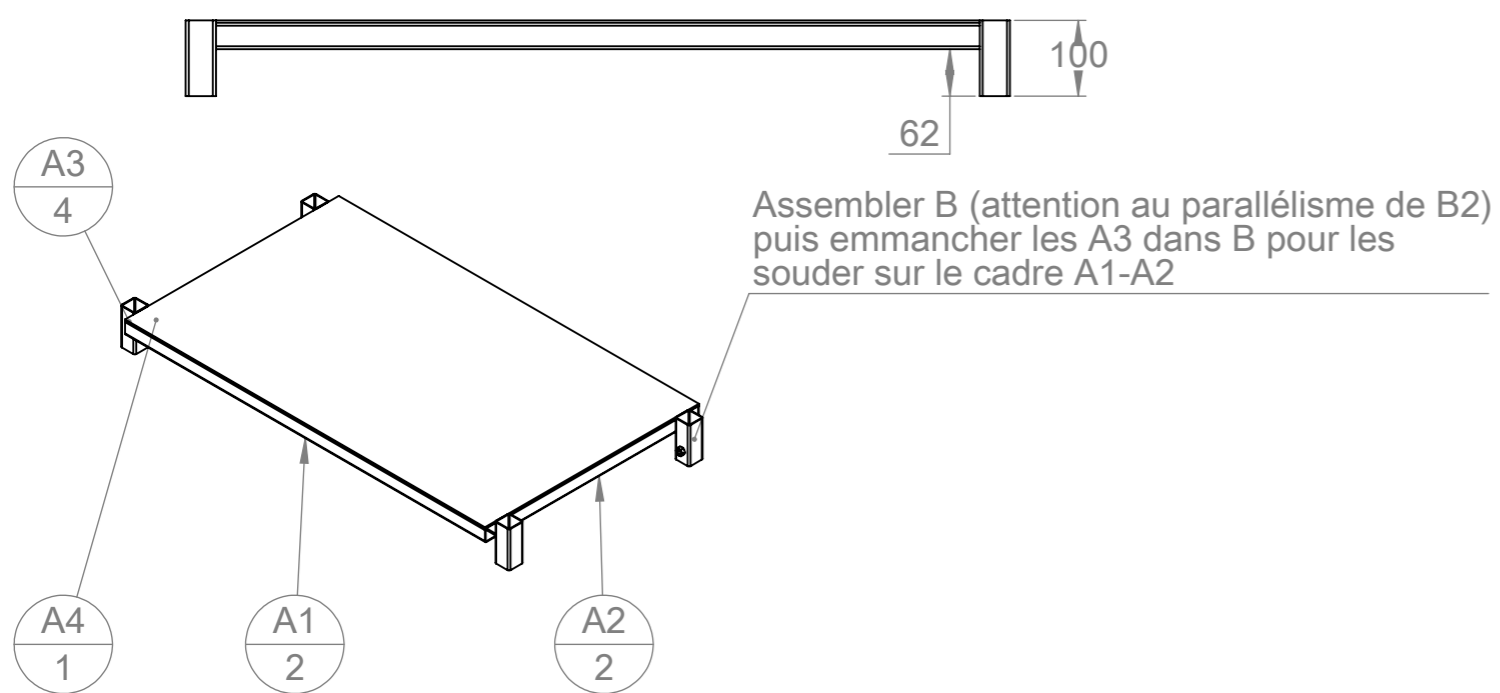
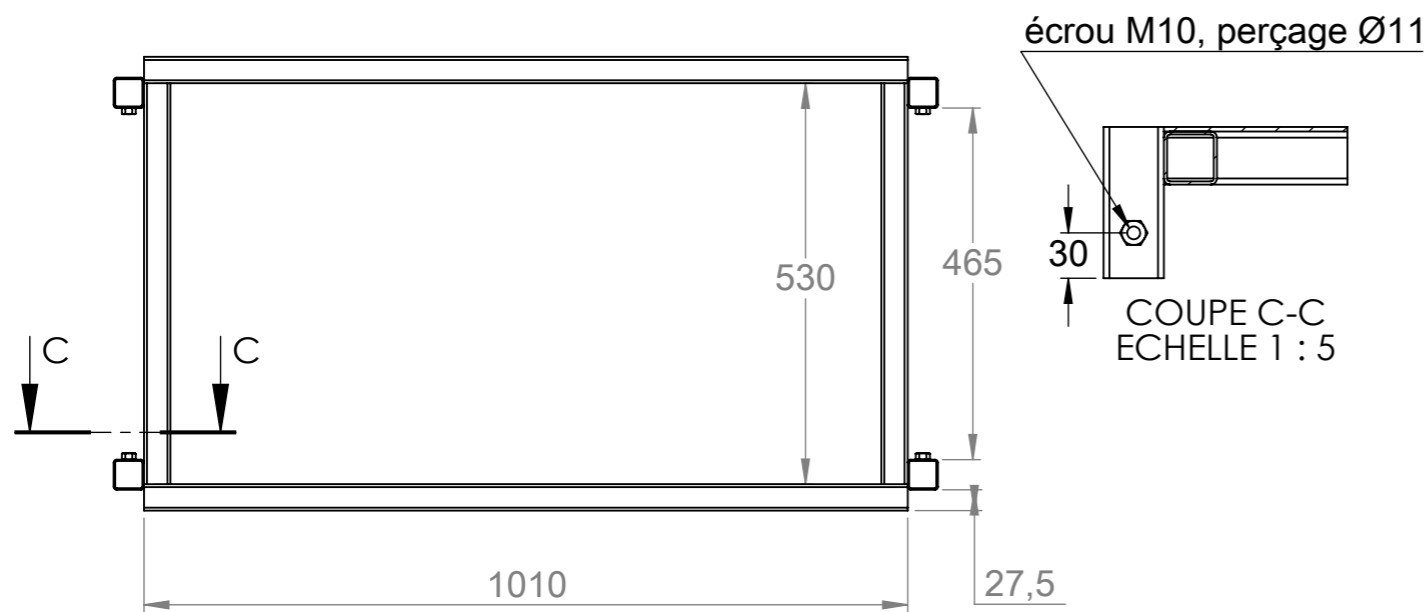

N°	Désignation	Longueur	Qté
A1	tube carré 35 x 2	1010	2
A2	tube carré 35 x 2	530	2
A3	tube carré 40 x 2	100	4
A4	tôle 1010*600*3mm		1
Ecrou	Ecrou M10 brut		4

