

# Moyeu

Matériau : acier C45 ou XC48

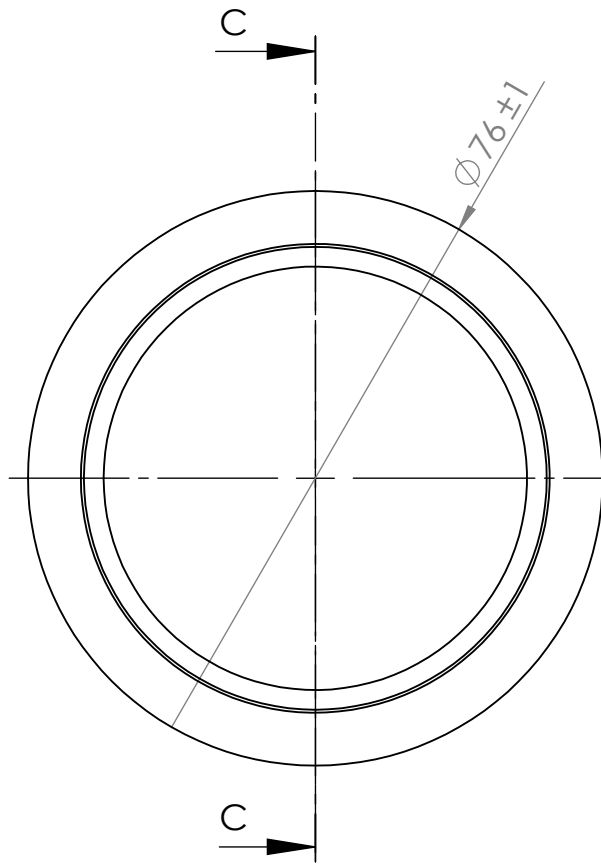

Bearing 6206

Bearing 6305

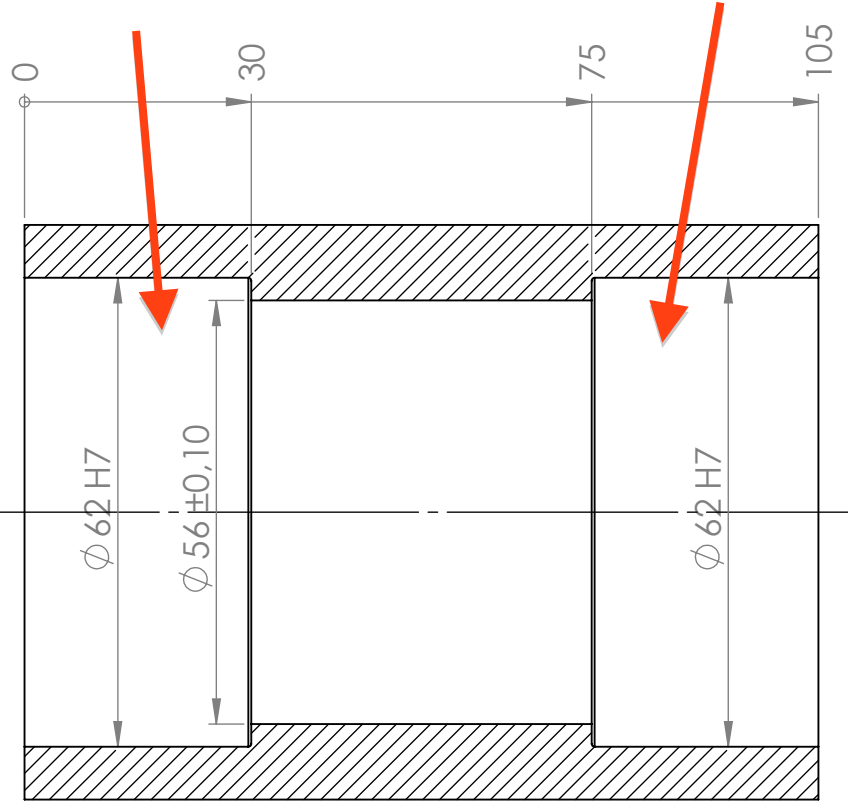

COUPE C-C

# Arbre

Matériau : acier mi-dur A60

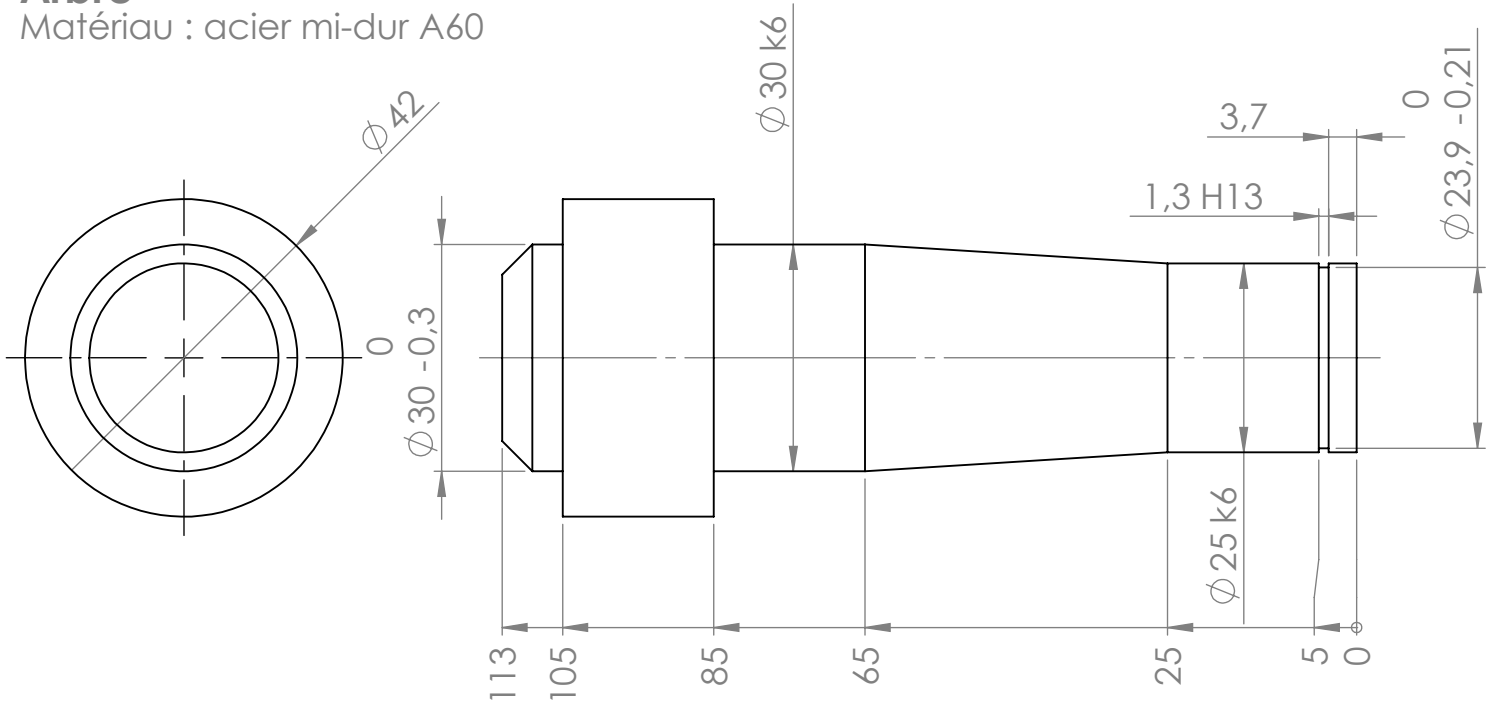

Tolérances générales :  $\pm 0,25$  mm

TITRE:

## Corps et Arbre

No. DE PLAN

A4

ECHELLE: 1:1

FEUILLE 1 SUR 1