

Date 19/12/2016

Version 1.3

Outil bride simple

Pièce

vue d'ensem

p : 1 / 4

Qté 1



Fonds Européen Agricole  
pour le Développement Rural  
(FEDER) 2014-2020



# ***BRIDE DISQUE BUTEUR***

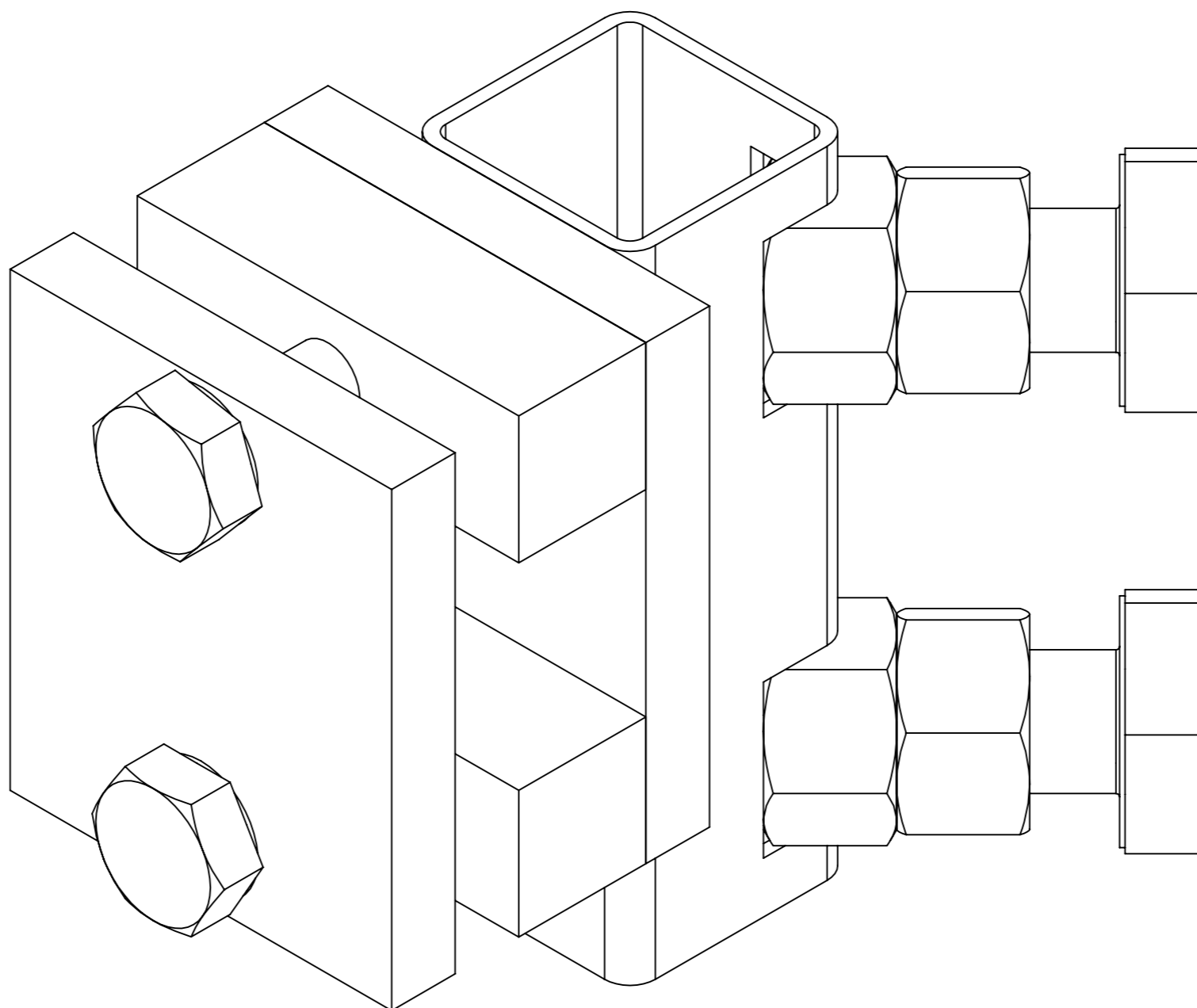

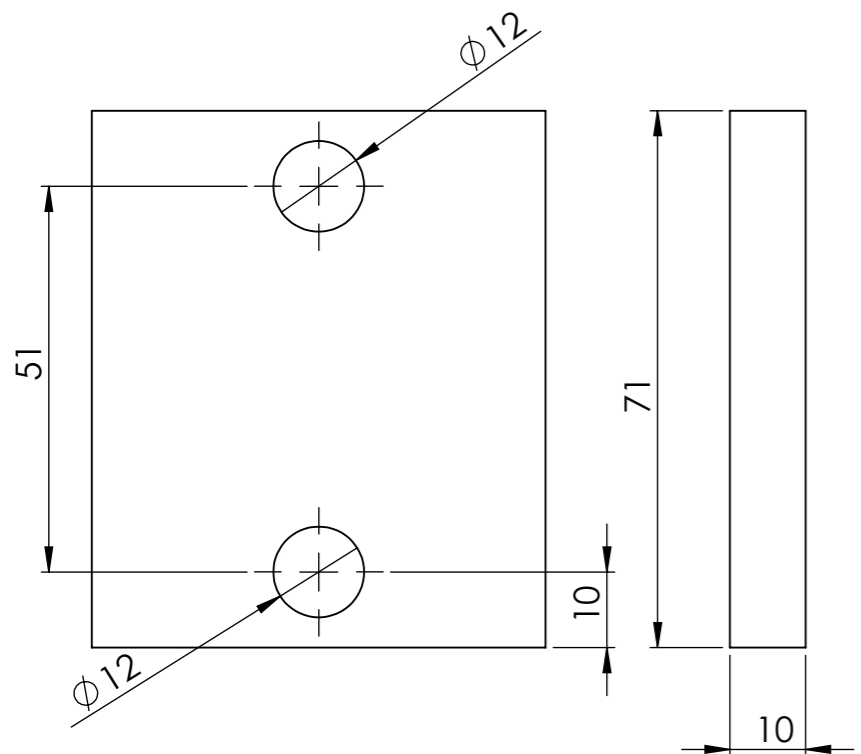

**Découpe laser**

Peut être fait main avec du ferplat de 60x10mm

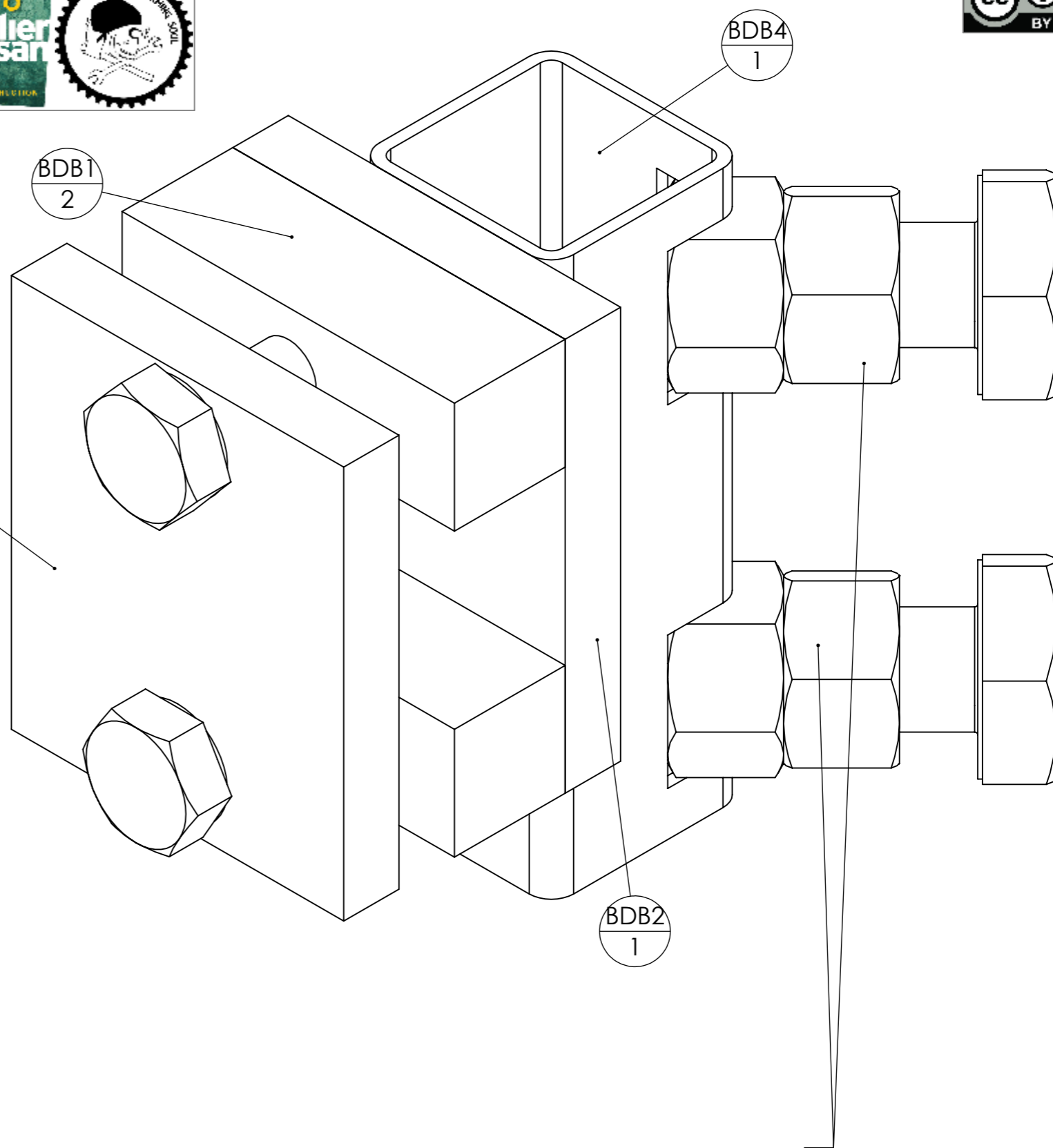

NUMERO DE PIECE	DESCRIPTION	Longueur	QTE
BDB1	étiré plat 20 x 20	60	2
BDB2	fer plat 60 x 10	71	1
BDB4	tube carré 35 x 2	100	1
BDB3	découpe laser		1
Vis Hexagonale	vis hexagonale M10 x 30		2
Ecrou	Ecrou M16 brut		1
Ecrou	Ecrou M16 Zingué		3
Vis Hexagonale	Vis hexagonale M16 x 50		2

Contre écrou M16 vissé

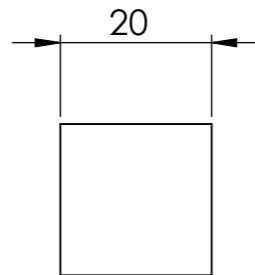
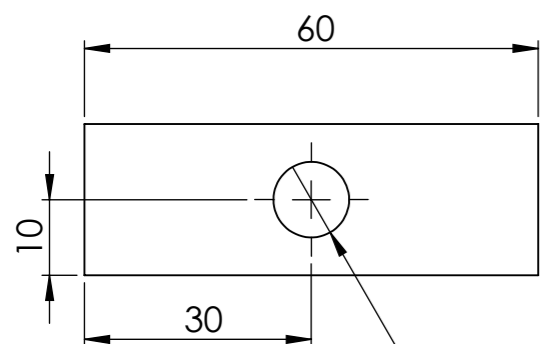

Perçage M8,5 pour taraudage M10

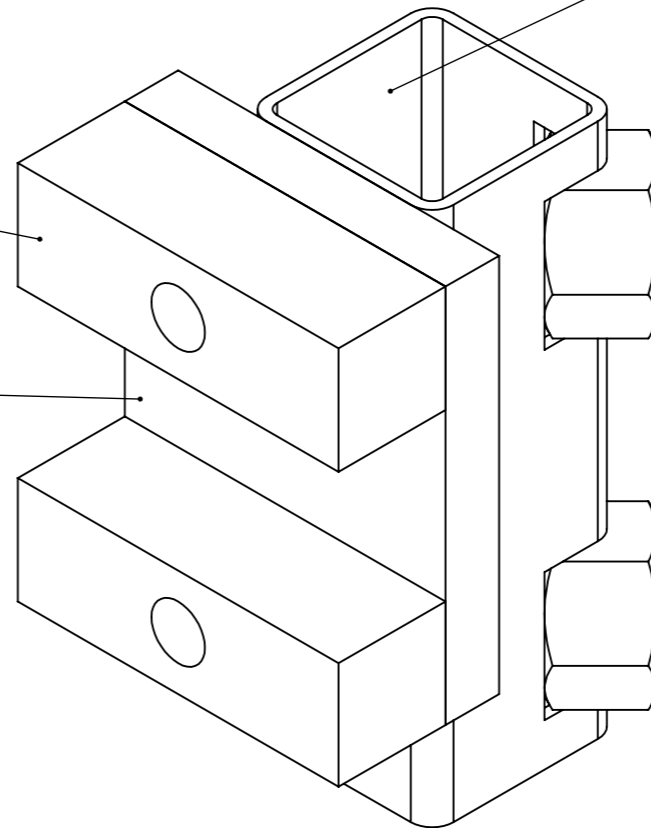
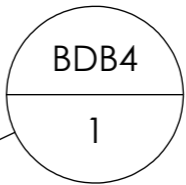
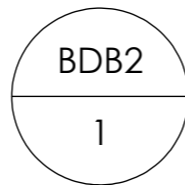
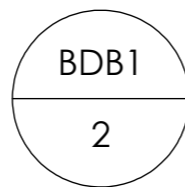

écrou M16 soudé dans l'angle, dans les réservations faites à la disquese

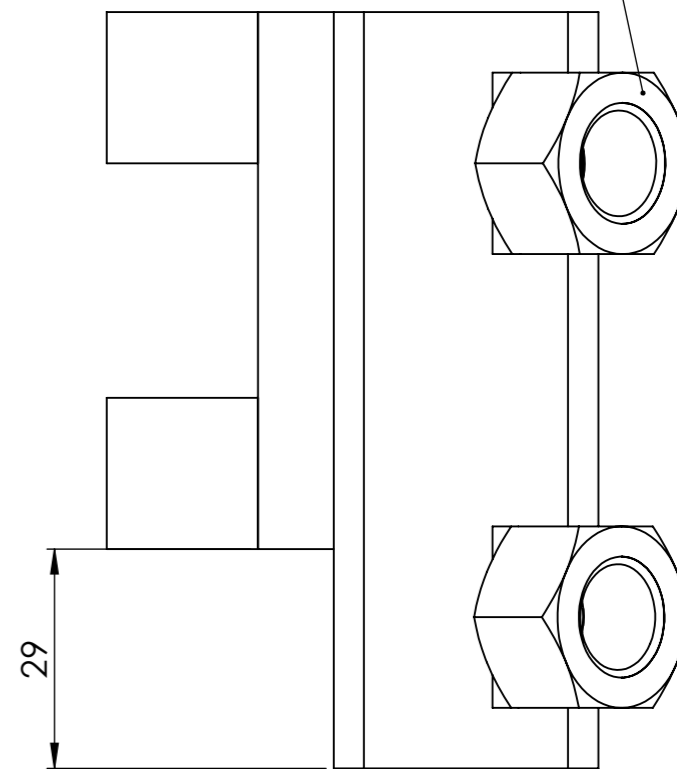
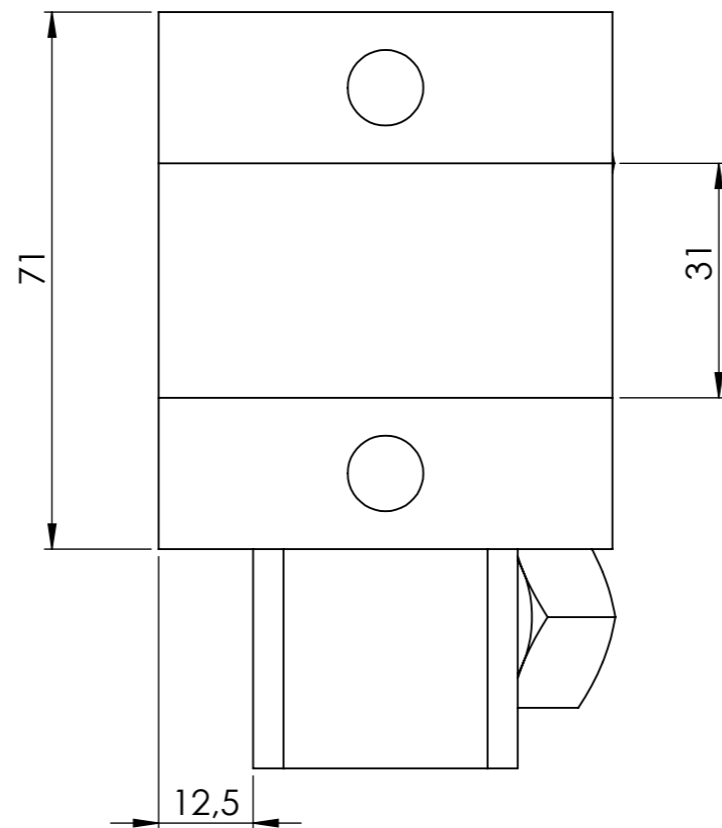
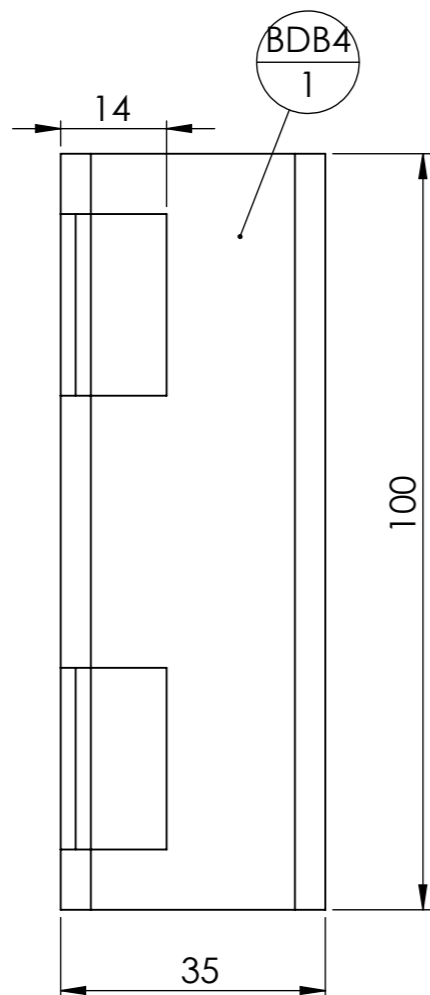
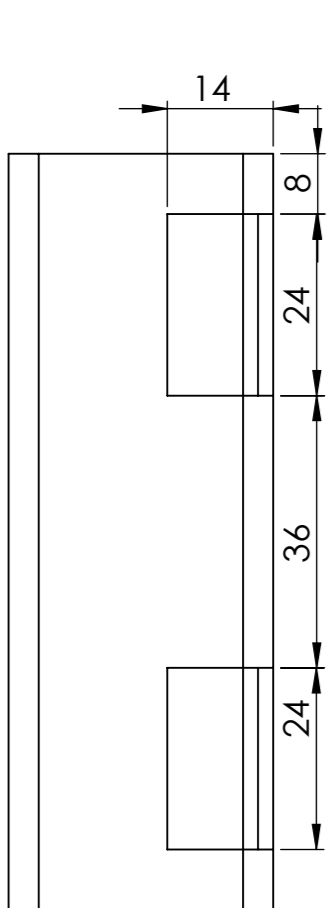

Date 19/12/2016

Version 1.3



Fonds Européen Agricole pour le Développement Rural : l'Europe investit dans les territoires



Outil bride simple Pièce Découpe laser p : 4 / 4 Qté 1

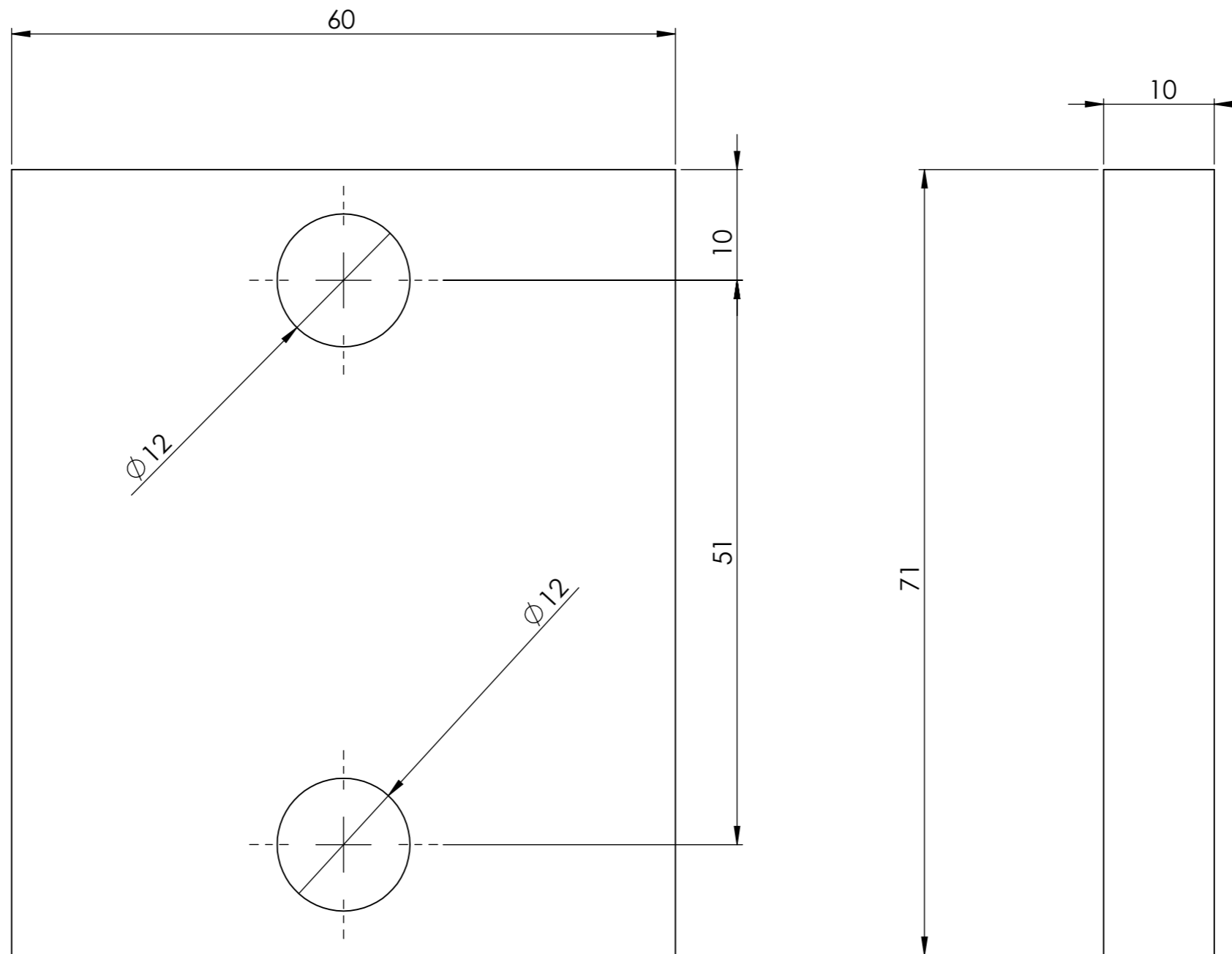

### Découpe laser

Peut être fait avec du ferplat de 60x10

NUMERO DE PIECE	DESCRIPTION	QTE
BDB3	découpe laser	1