

Date 19/12/2016

Version 1.3

Outil **CPO**

Logo République Française  
Logo Réseau Rural France 2014-2020  
Logo l'Europe songage en France avec le PADER  
Logo Fonds Européen Agricole pour le Développement Rural  
Logo Union Européenne

Logo l'atelier paysan  
Logo COOPÉRALITÉ D'ALTOUR JUSQU'À L'ÉTRANGER  
Logo FAIRNESS TOOL



# Cadre Porte Outil

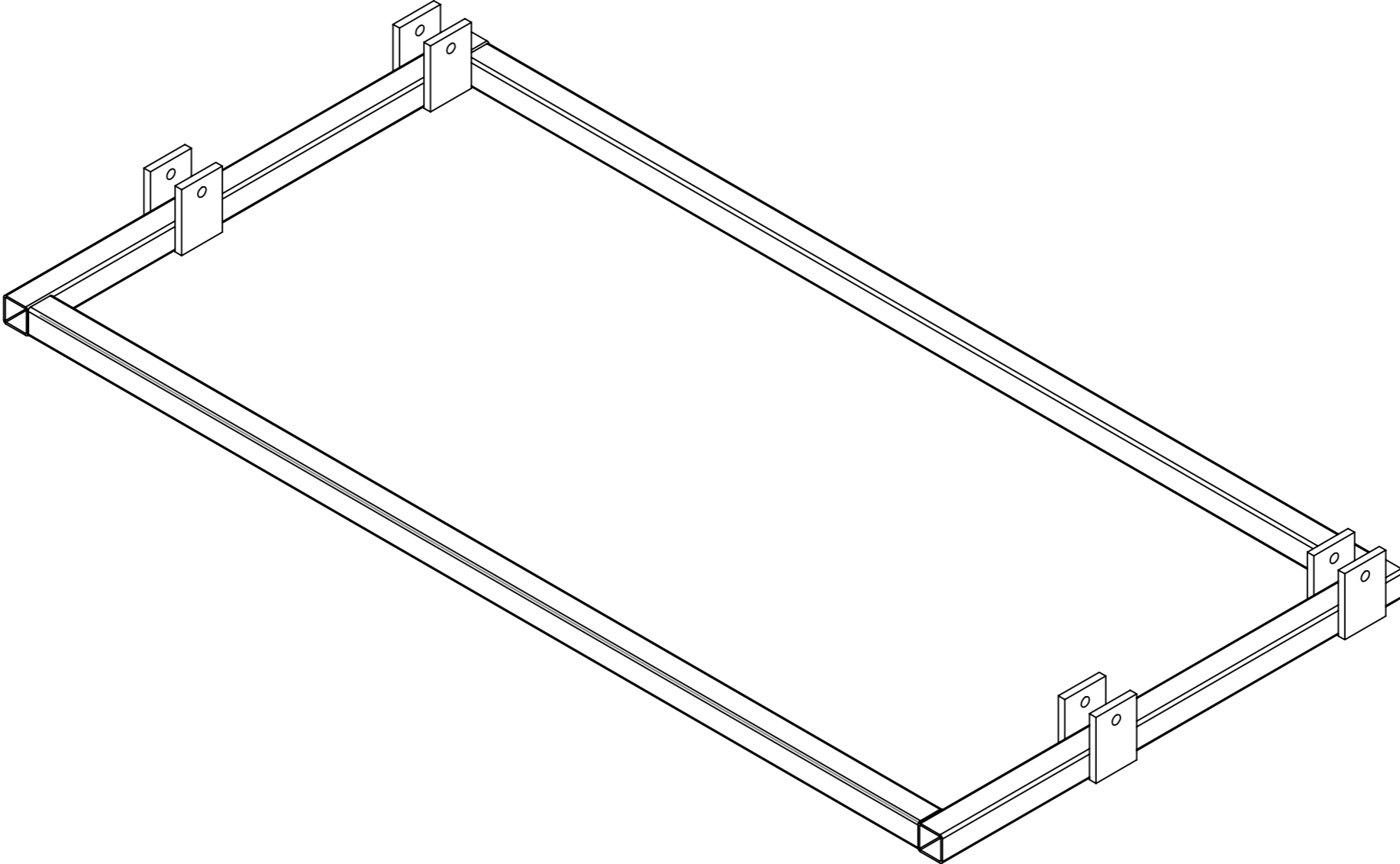

Date	19/12/2016
Version	1.3
Outil	<b>CPO</b>

Pièce	<b>Détails</b>	p : 2 / 3	Qté	1
-------	----------------	-----------	-----	---

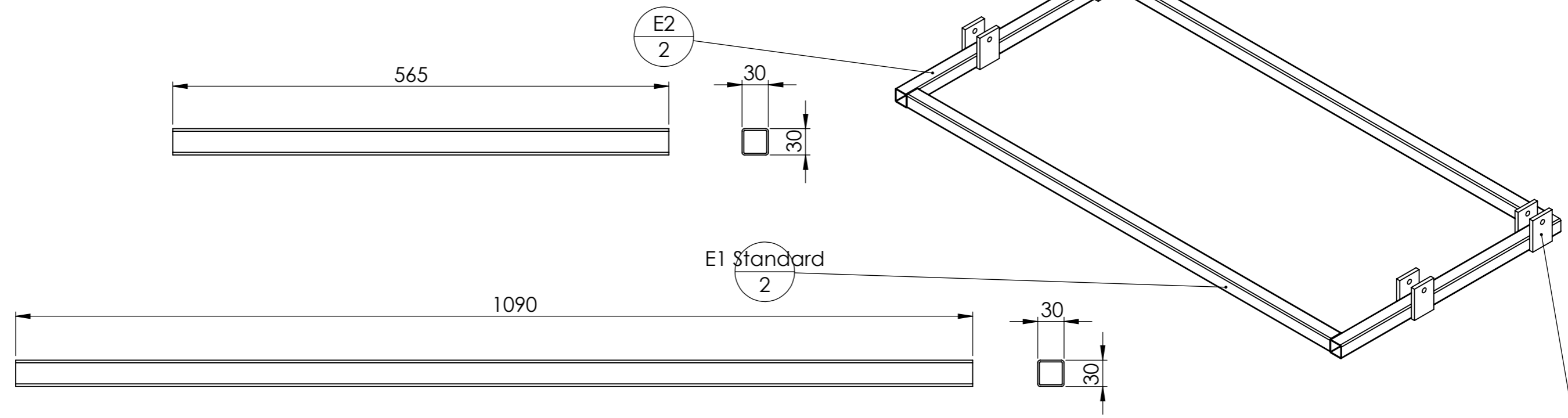

NUMERO DE PIECE	DESCRIPTION	Longueur	QTE
E1 Standard	Tube carré 30 x 2	1090	2
E2	Tube carré 30 x 2	565	2
E3	découpe laser		8

**Découpe laser**

**Version étroite**

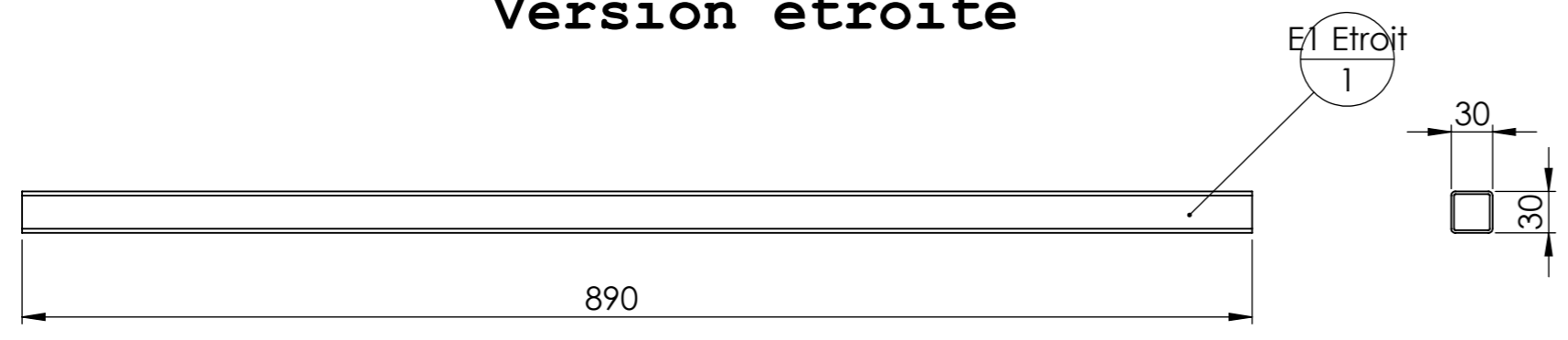

NUMERO DE PIECE	DESCRIPTION	Longueur	QTE
E2	Tube carré 30 x 2	565	2
E3	découpe laser		8
E1 Etroit	Tube carré 30 x 2	890	2

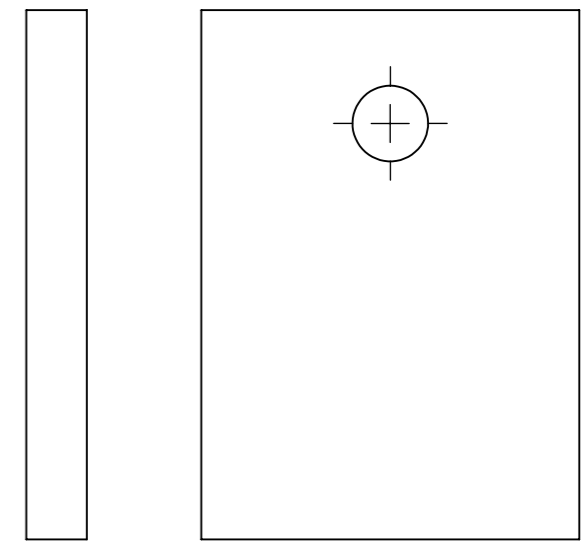

Date 19/12/2016

Version 1.3

Outil **CPO**

Pièce **Découpe laser** p : 3 / 3 Qté 1



Fonds Européen Agricole pour le Développement Rural

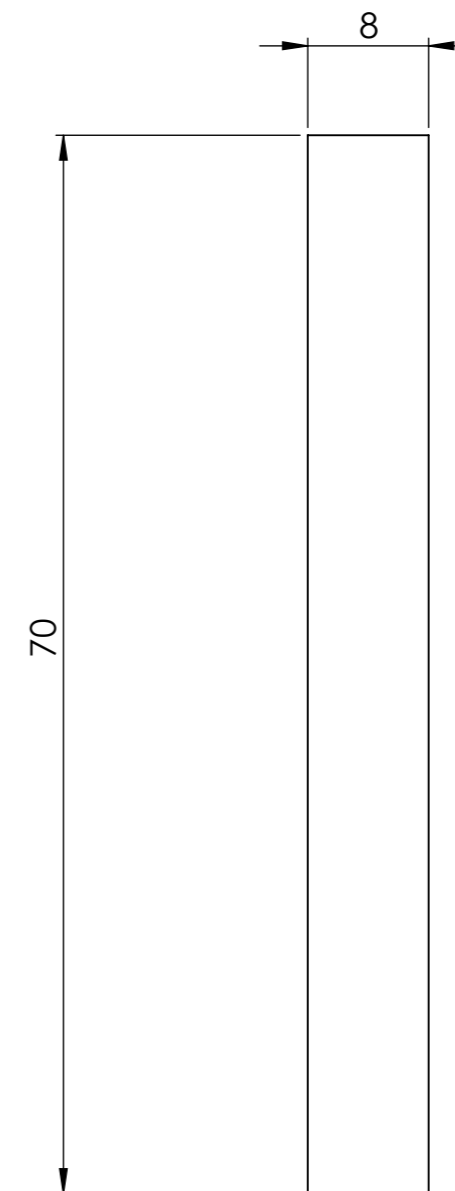
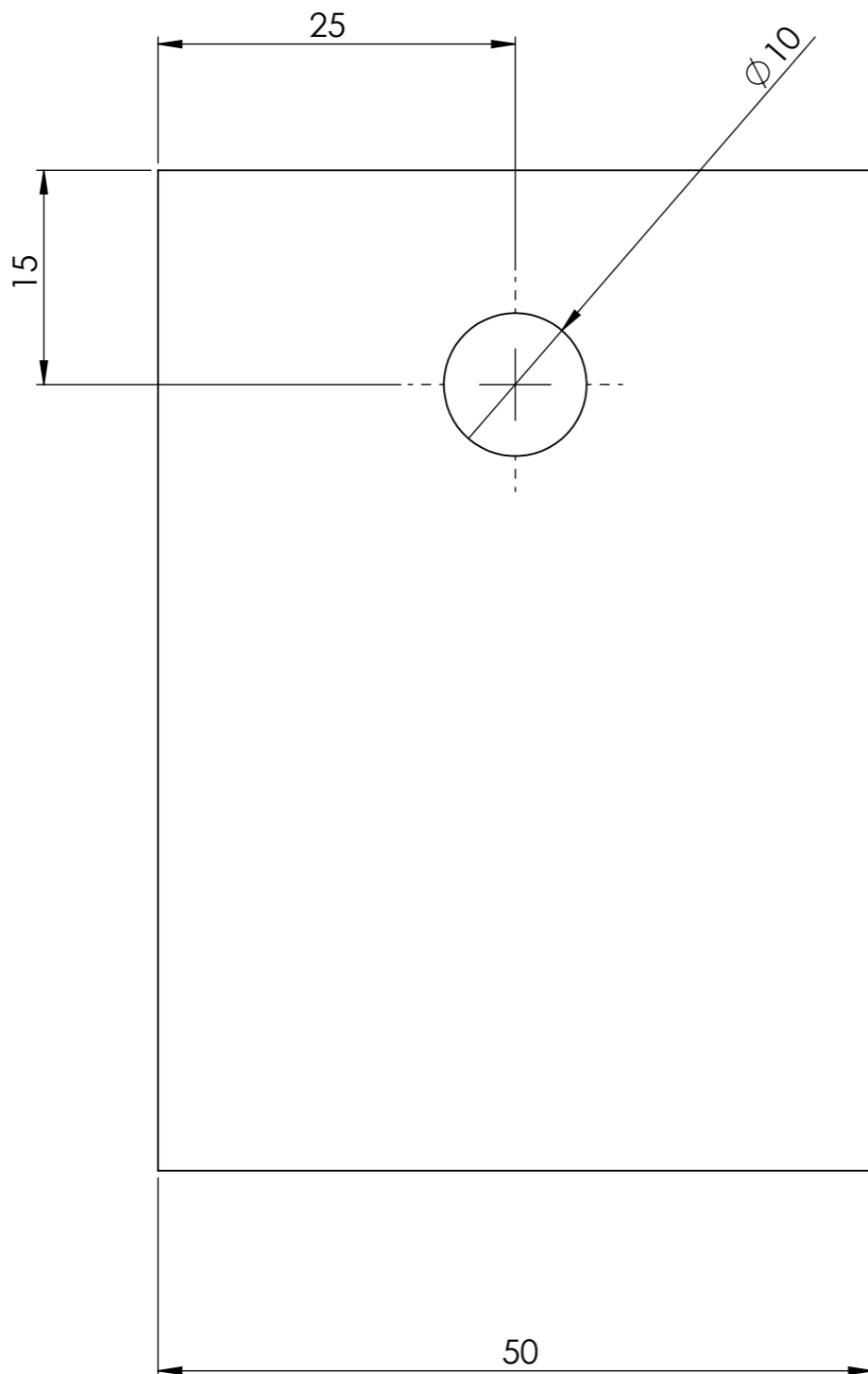

### E3 Découpe laser

Peut être fait dans du méplat de 50x5