

Version	1.0	Qté	1
Date	24/11:2014		
Outil	Néo Bucher		
Pièce	Pièces tournées		

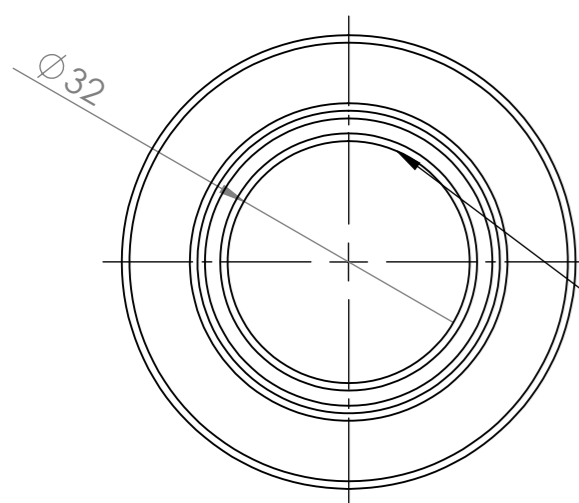

Ajustement pour emmanchement couissant avec pièce male, Montage régulier

N°	Désignation	Longueur	Qté
C1.4	Emmanche Outil Femelle Tourné A60		2

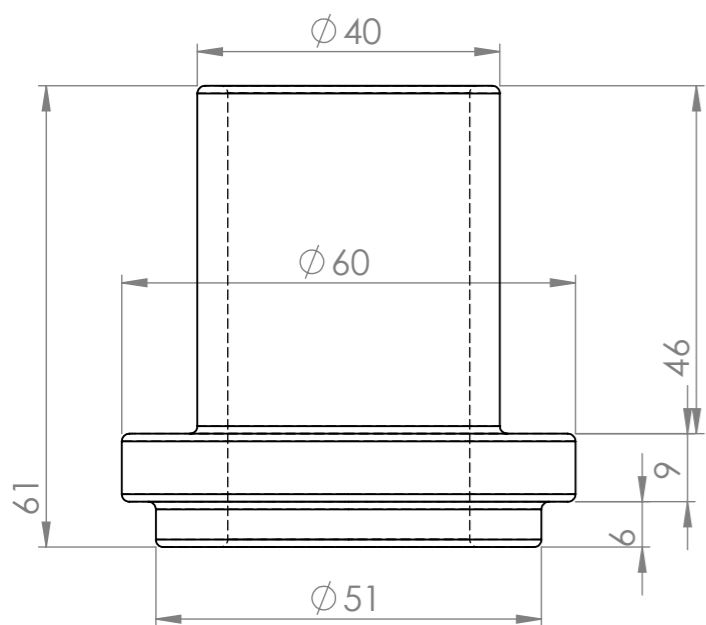
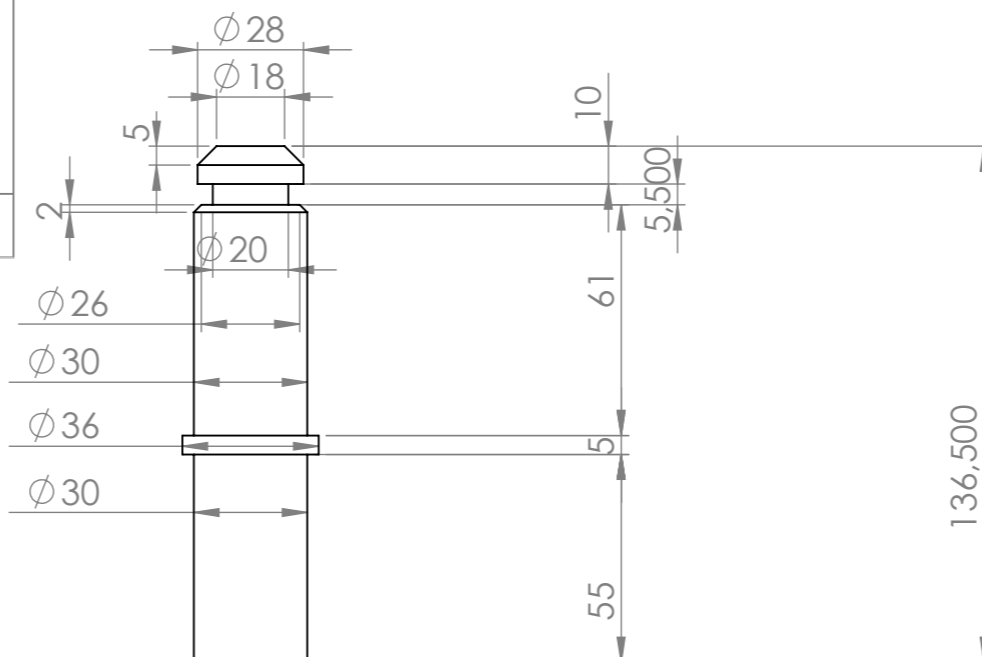

N°	Désignation	Longueur	Qté
C6.2	Emmanche Outil Male Tourné, Acier A60		6

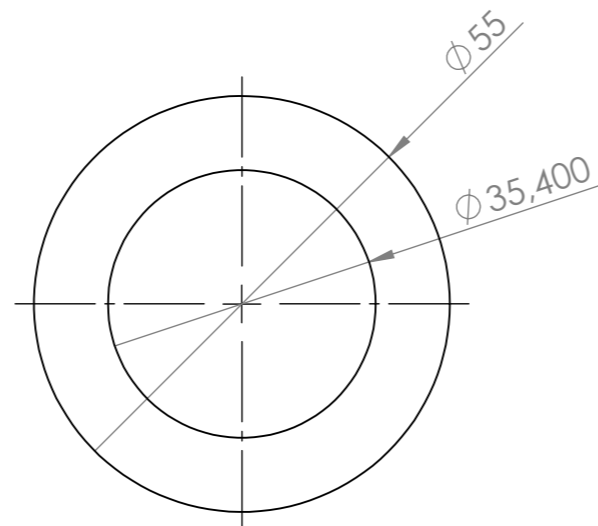

N°	Désignation	Longueur	Qté
	Moyeux diam. 35		
	Moyeu ext 55 int 35 l60		2

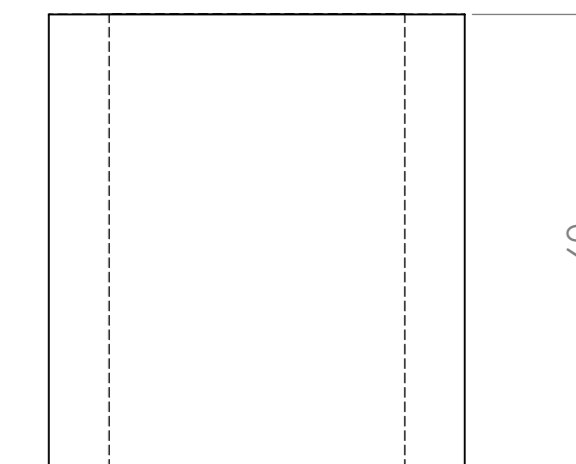
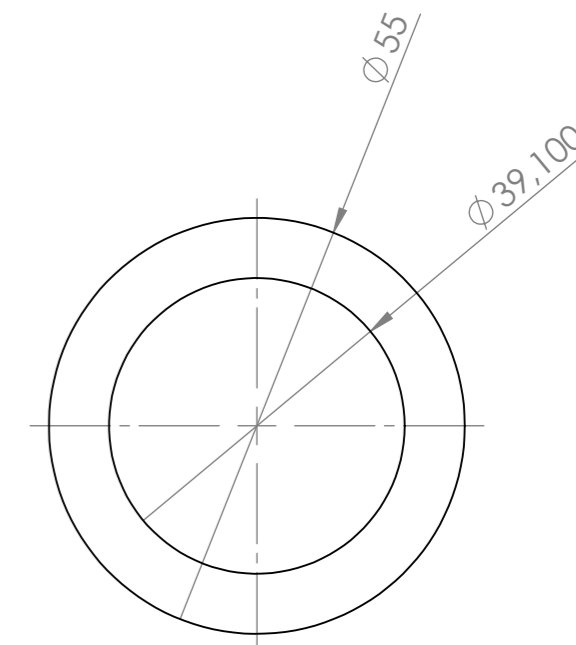

N°	Désignation	Longueur	Qté
	Moyeux diam.39		
	Moyeu ext 55 int 39.1 l60		2

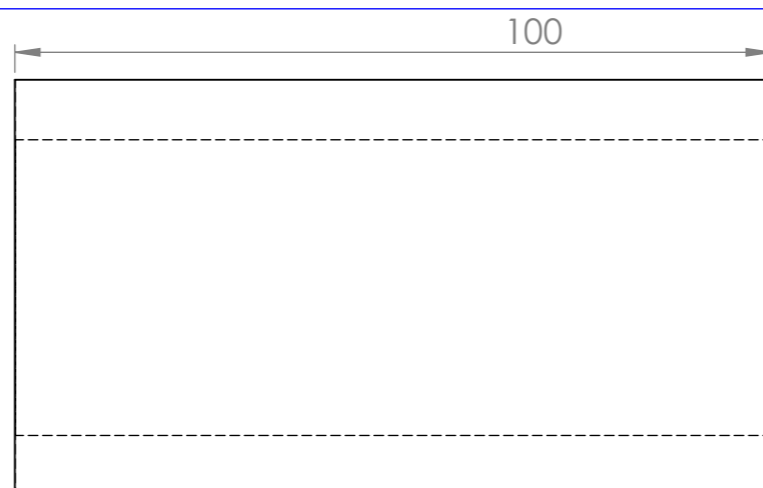
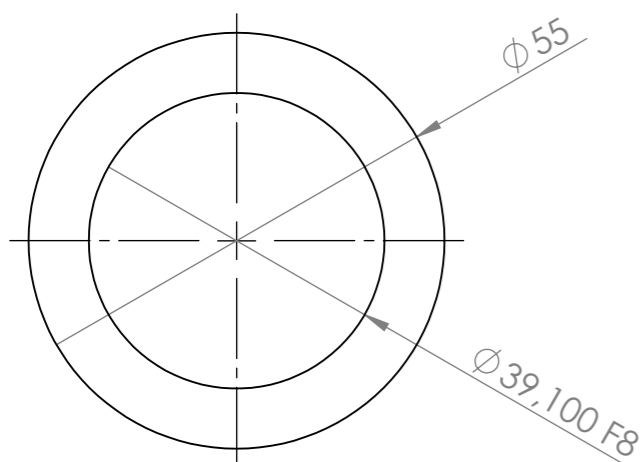

N°	Désignation	Longueur	Qté
	Moyeu tourné		
	Moyeu ext 55 int 35 l100, A60	100	4