

Date 19/12/2016

Version 1.3

Outil **Rouleau**

Pièce

Vue générale

p : 1 / 8

Qté 1



Fonds Européen Agricole pour le Développement Rural : l'Europe investit dans le territoire



ROULEAU EMIETTEUR

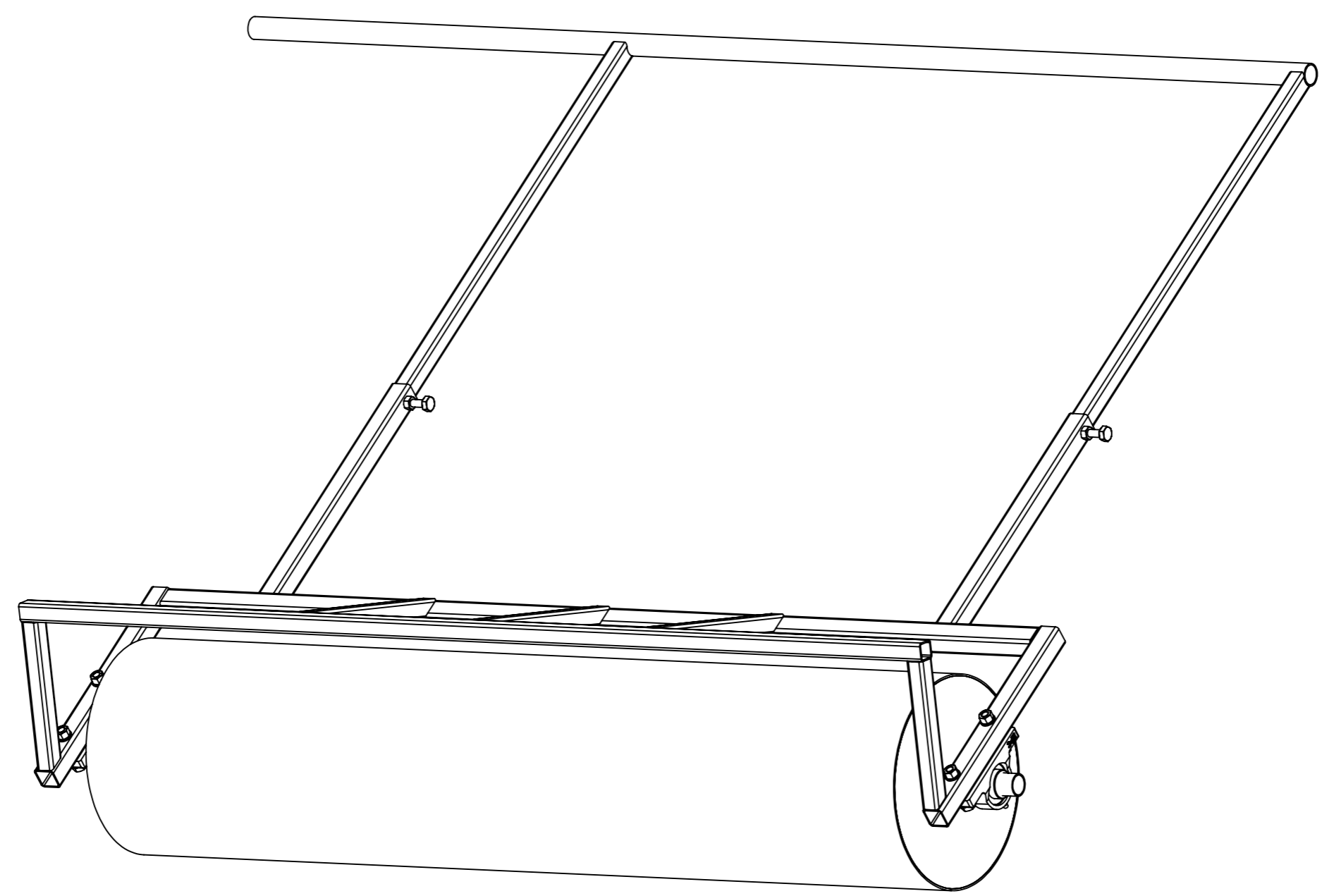

Date 19/12/2016
Version 1.3



Outil **Rouleau** Pièce **détail** p : 2 / 8 Qté 1

NUMERO DE PIECE	DESCRIPTION	Longueur	QTE
RM2	Tube carré 30 x 2	350	2
RM7	Tube carré 30 x 2	400	2
RM3	tube carré 25 x 2	200	2
RM6	tube carré 25 x 2	280	3
Ecrou	Ecrou M10 brut		2
RM1standard	Tube carré 30 x 2	1400	1
RM4 standard	tube carré 25 x 2	1450	1
Palier Ø30	Palier chapeau Ø30		2
Rondelle	Rondelle Ø10 série ZU		8
Vis Hexagonale	M10x60		4
Ecrou	Ecrou M10 autofreiné		4
Axe standard	tube rond 30 x 2	1500	1
disque	découpe laser		4
fer déployé standard	ép3mm, 60x40x5mm		1
P1	tube carré 25 x 2	950	2
P2 standard	tube rond 30 x 2	1700	1
Vis Hexagonale	vis hexagonale M10 x 30		2

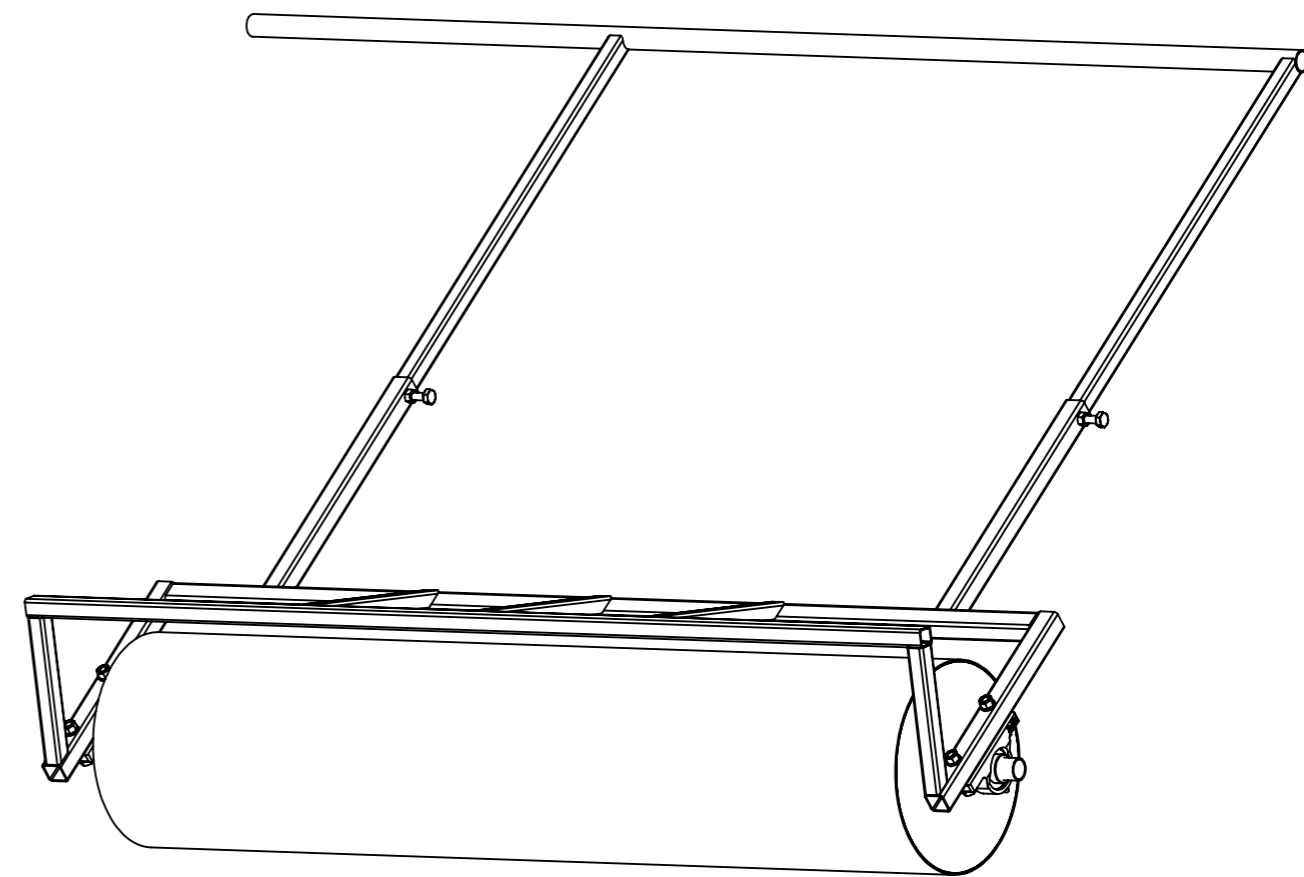

NUMERO DE PIECE	DESCRIPTION	Longueur	QTE
RM1étroit	Tube carré 30 x 2	1200	1
RM4 étroit	tube carré 25 x 2	1250	1
Axe étroit	tube rond 30 x 2	1300	1
fer déployé étroit	ép3mm, diagonale 62x30mm		1
Rondelle	Rondelle Ø10 série ZU		8
P2 étroit	tube rond 30 x 2	1500	1

Date	19/12/2016
Version	1.3
Outil	Rouleau

Pièce	Rouleau1	p : 3 / 8	Qté	1
-------	-----------------	-----------	-----	---

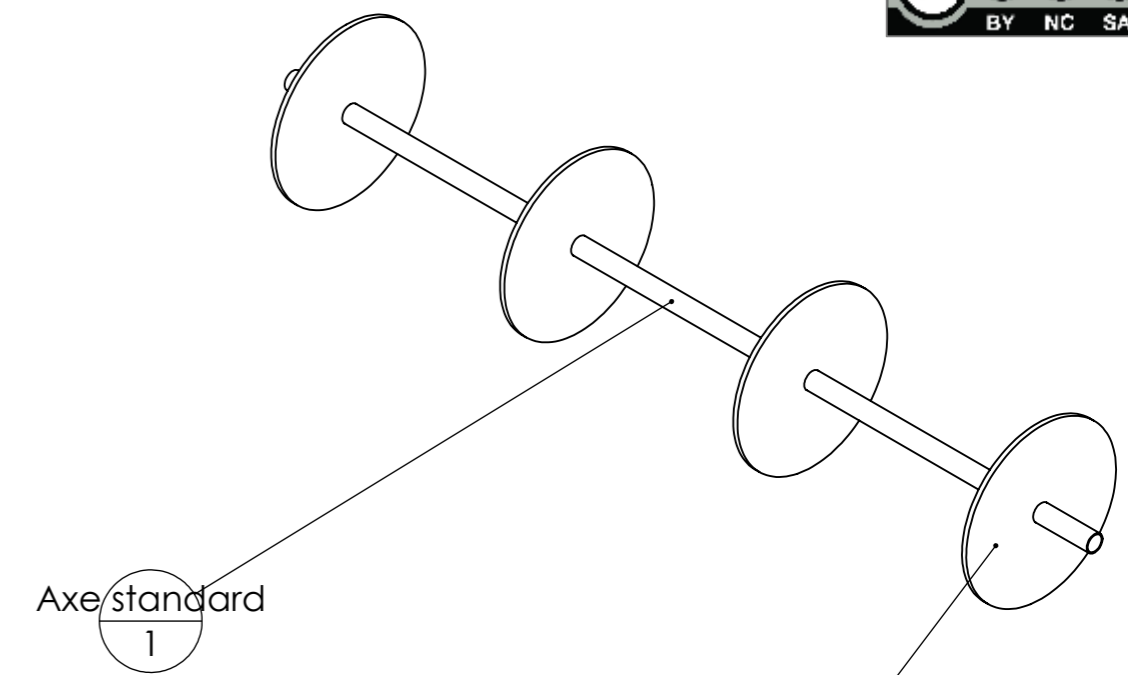
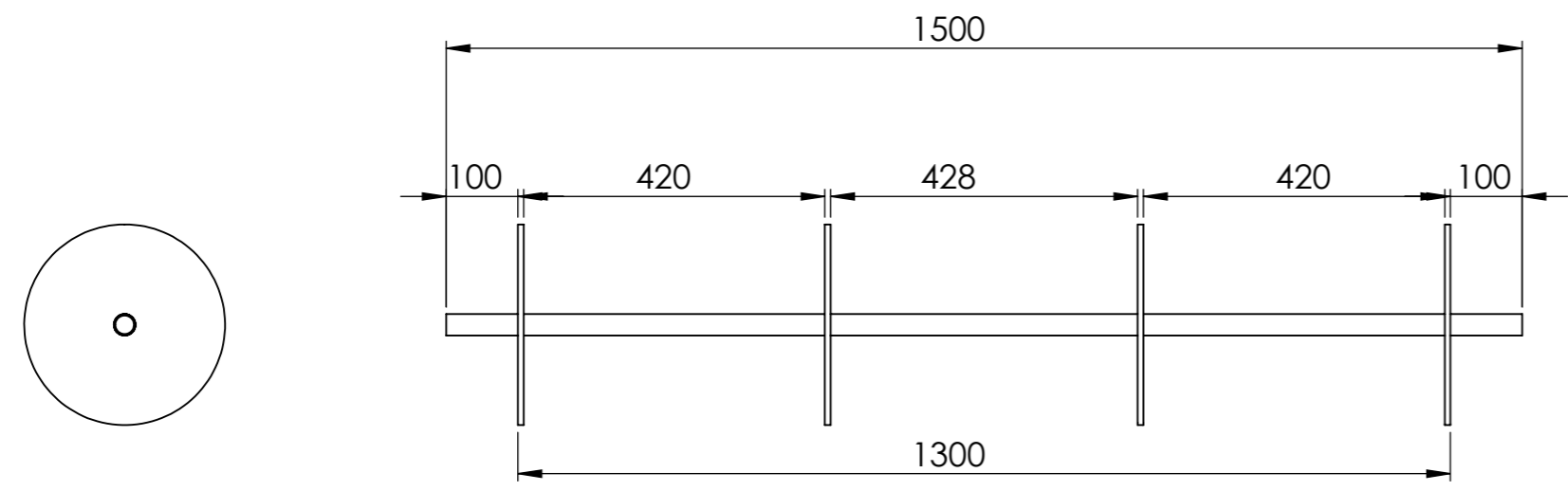

NUMERO DE PIECE	DESCRIPTION	Longueur	QTE
Axe standard	tube rond 30 x 2	1500	1
disque	découpe laser		4

VERSION ETROITE

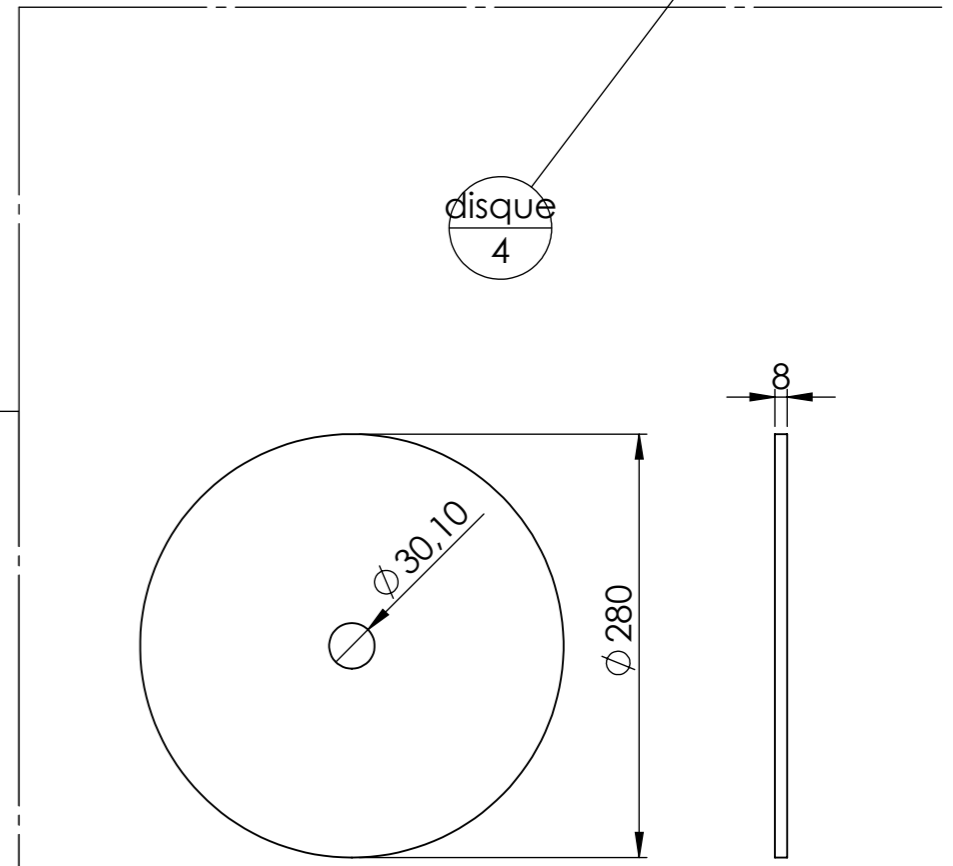
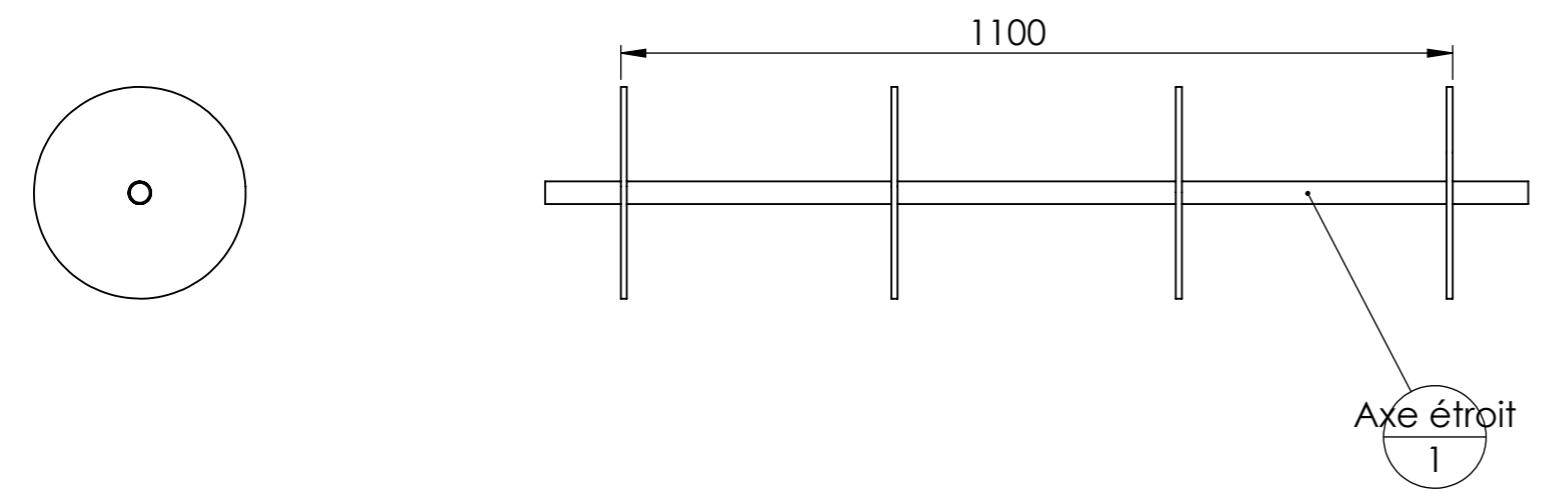

Découpe laser

NUMERO DE PIECE	DESCRIPTION	Longueur	QTE
Axe étroit	tube rond 30 x 2	1300	1
disque	découpe laser		4

Fer déployé découpe standard

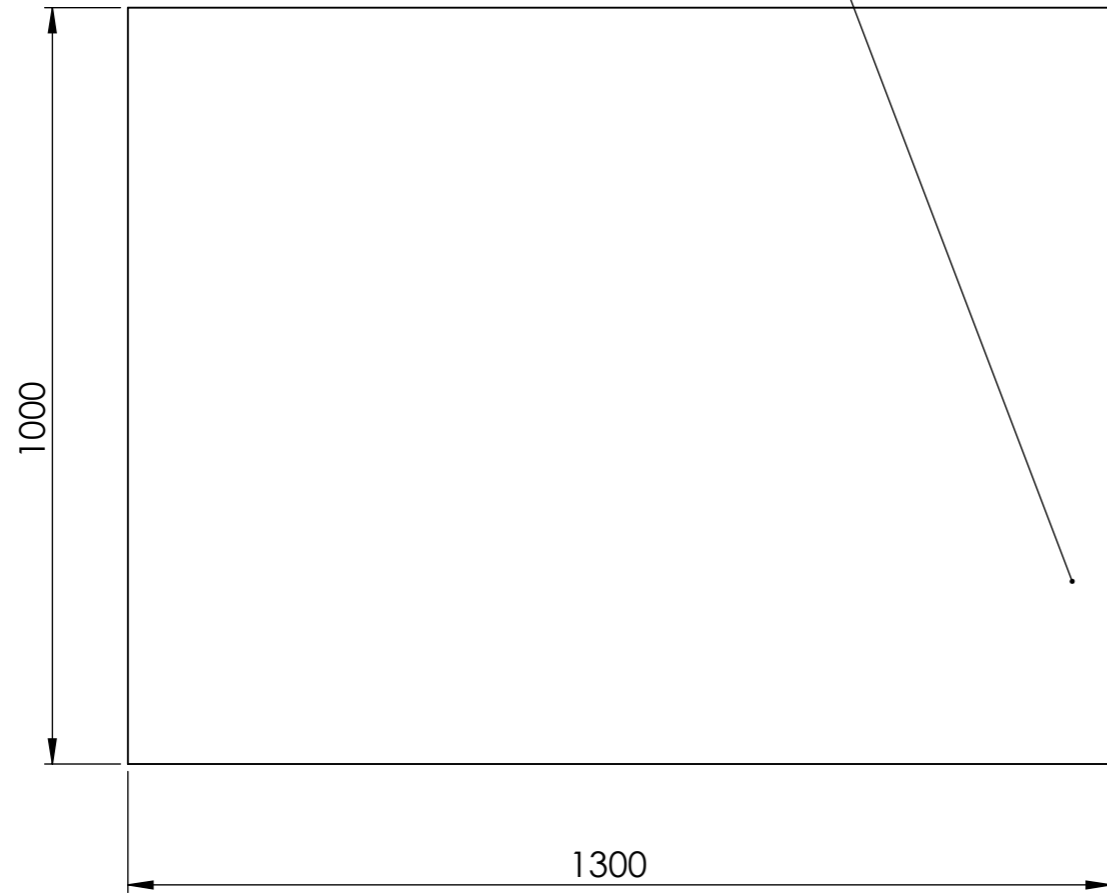

Fer déployé découpe étroit

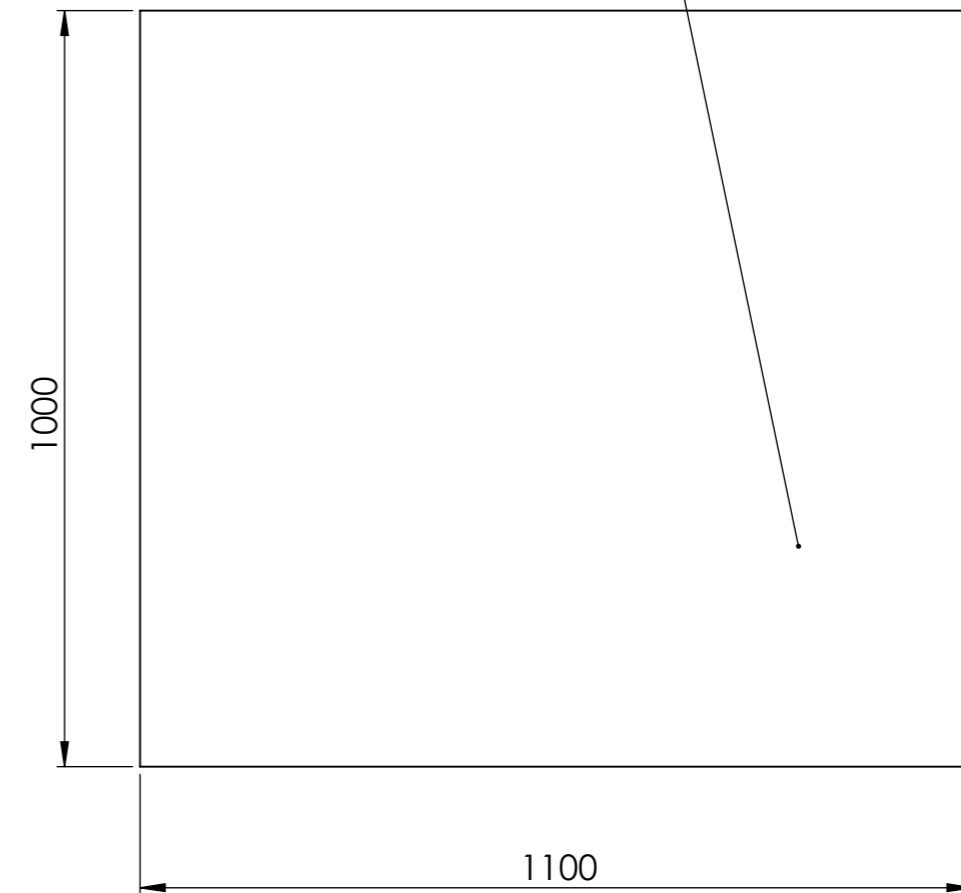

On utilise du fer déployé d'épaisseur 3mm et de diagonale 60x40mm. On vient souder cette grille sur les 4 disques soudés sur l'axe.

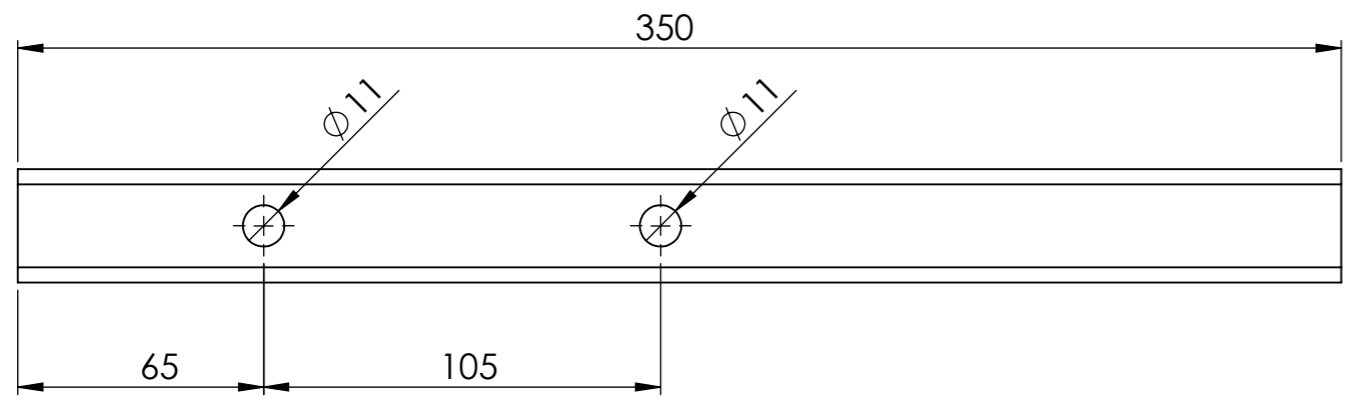

RM2
2

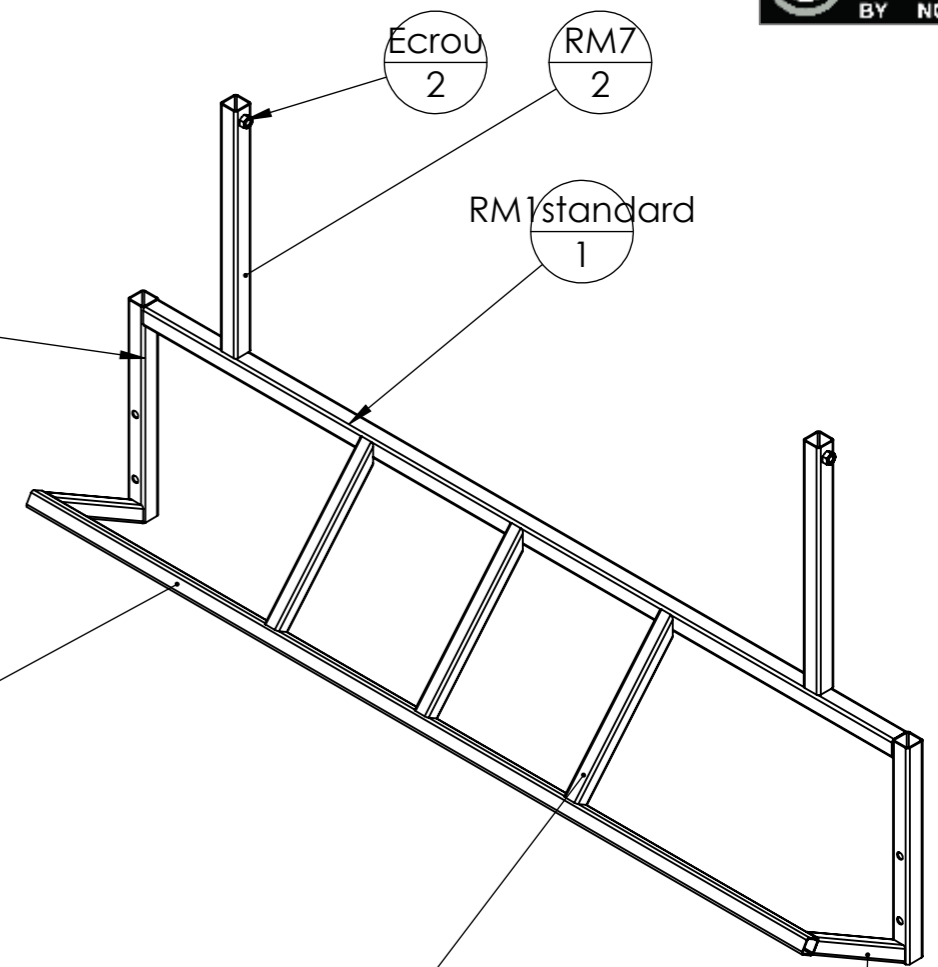

Ecrou
2

RM7
2

RM1 standard
1

RM4 standard
1

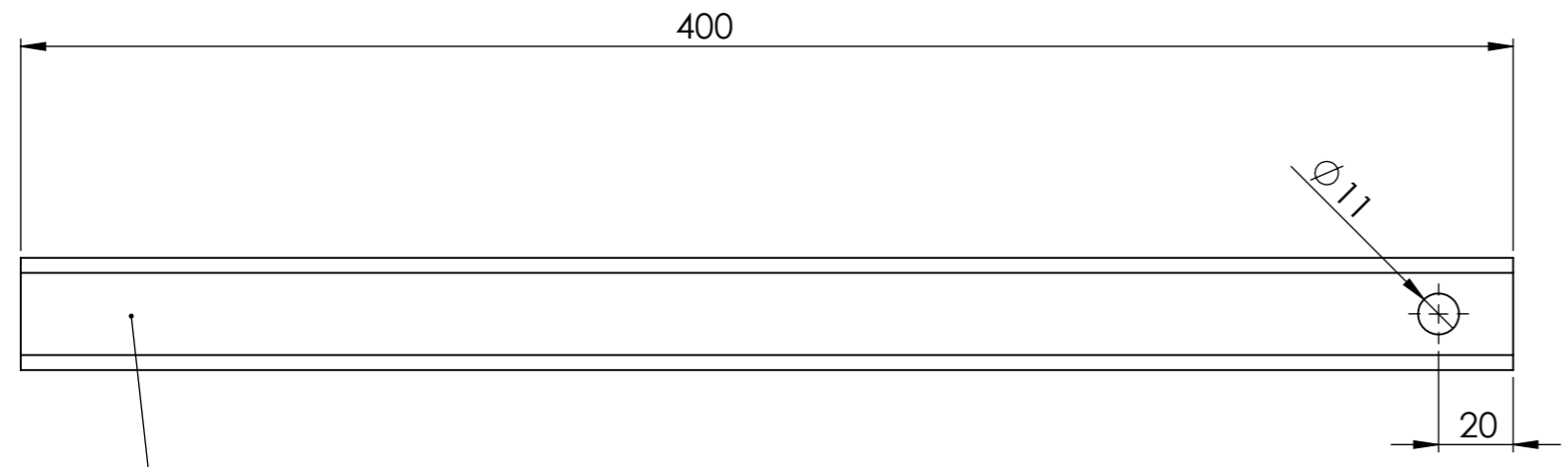

RM7
1

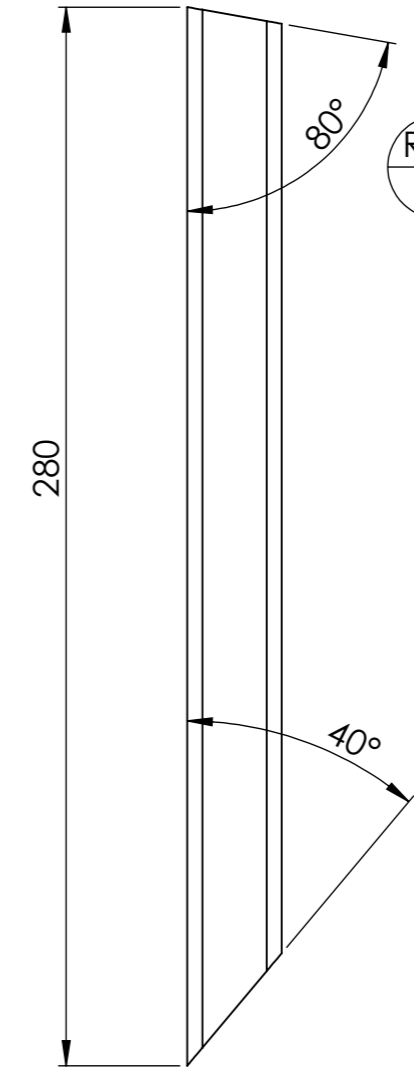

RM6
3

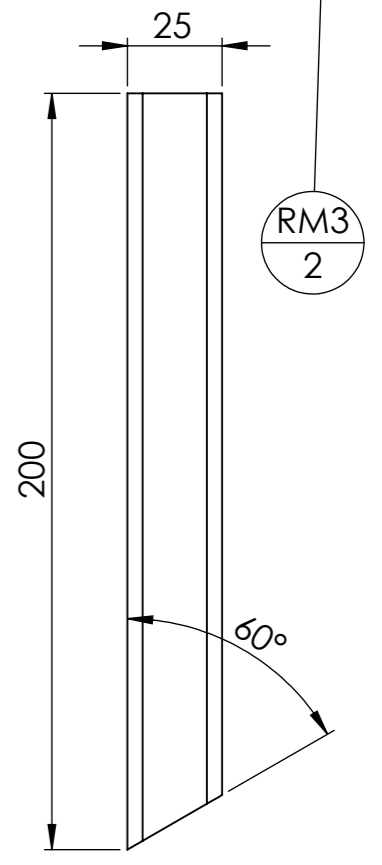

RM3
2

NUMERO DE PIECE	DESCRIPTION	Longueur	QTE
RM2	Tube carré 30 x 2	350	2
RM7	Tube carré 30 x 2	400	2
RM3	tube carré 25 x 2	200	2
RM6	tube carré 25 x 2	280	3
Ecrou	Ecrou M10 brut		2
RM1 standard	Tube carré 30 x 2	1400	1
RM4 standard	tube carré 25 x 2	1450	1

Date 19/12/2016

Version 1.3



Outil **Rouleau** Pièce **relevage 2** p : 6 / 8 Qté 1

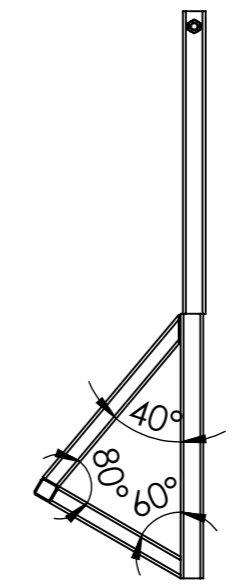
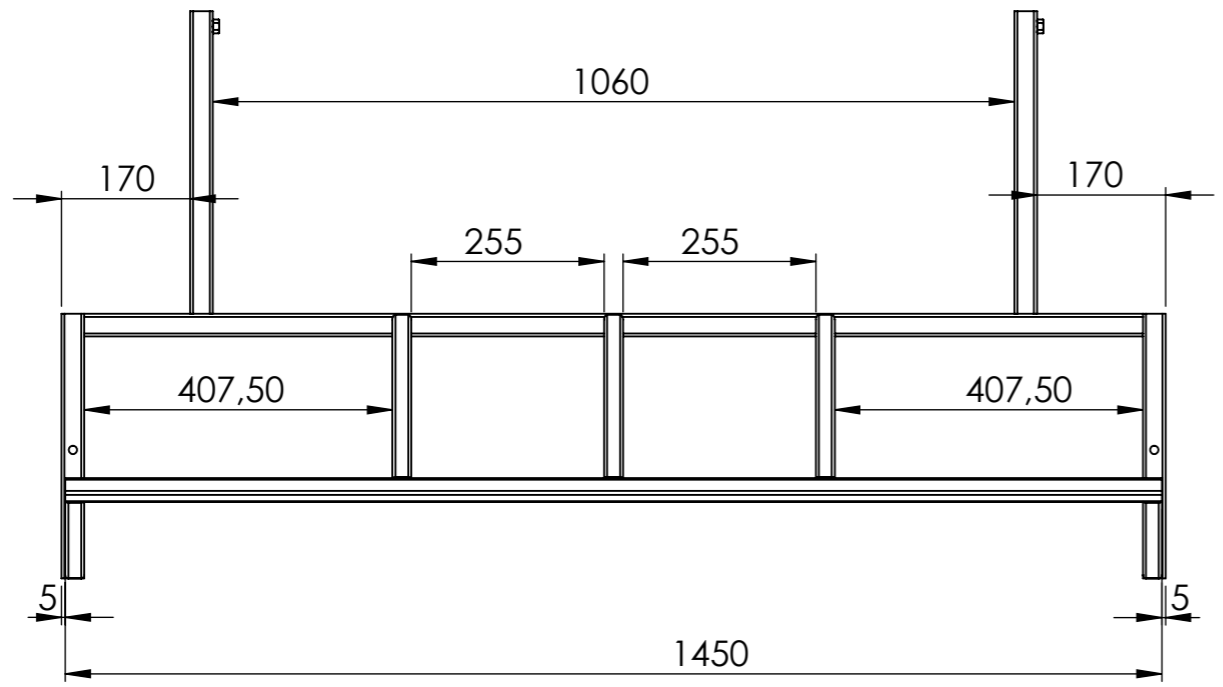

VERSION ETROITE

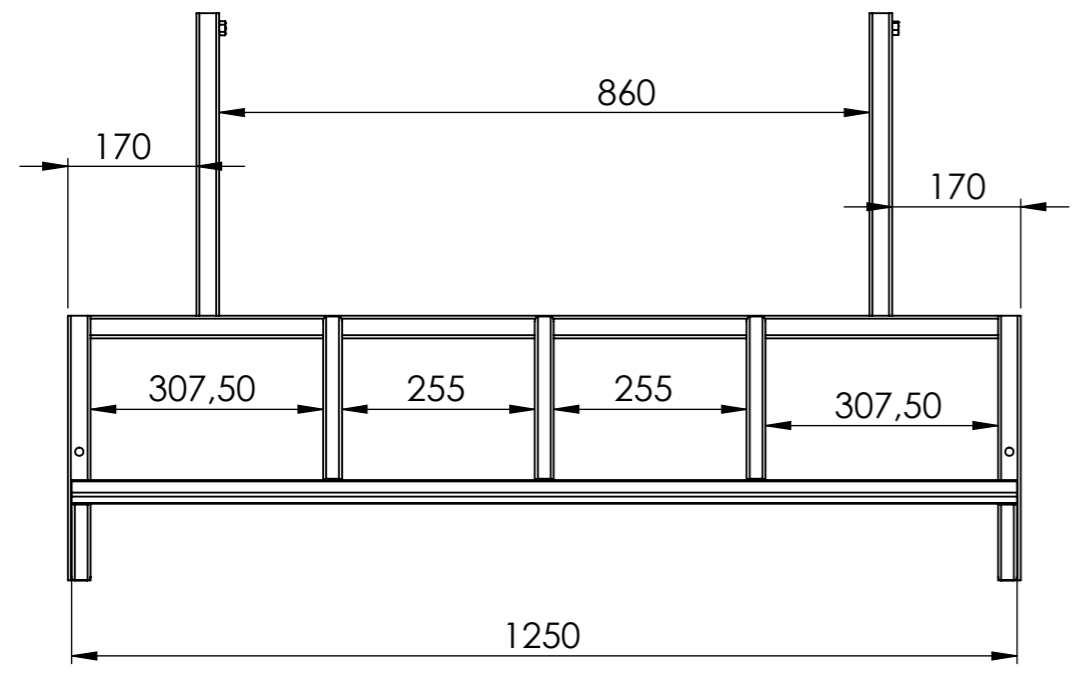

NUMERO DE PIECE	DESCRIPTION	Longueur	QTE
RM1étroit	Tube carré 30 x 2	1200	1
RM2	Tube carré 30 x 2	350	2
RM7	Tube carré 30 x 2	400	2
RM3	tube carré 25 x 2	200	2
RM4 étroit	tube carré 25 x 2	1250	1
RM6	tube carré 25 x 2	280	3
Ecrou	Ecrou M10 brut		2

Date 19/12/2016

Version 1.3

Outil **Rouleau**







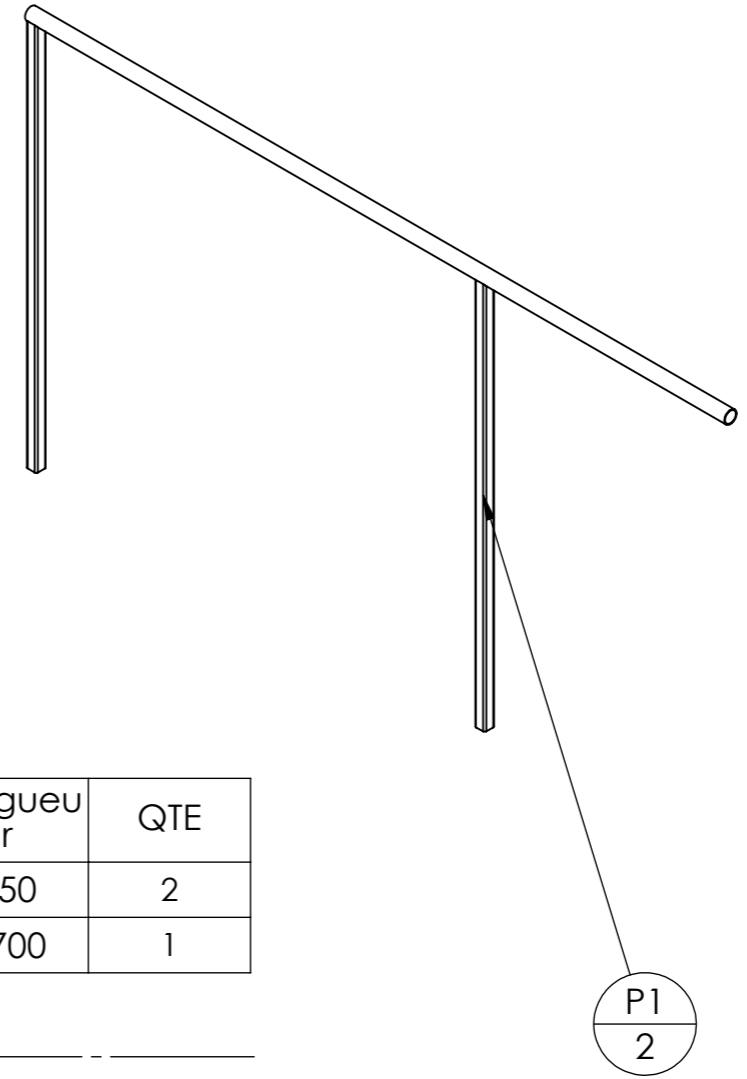
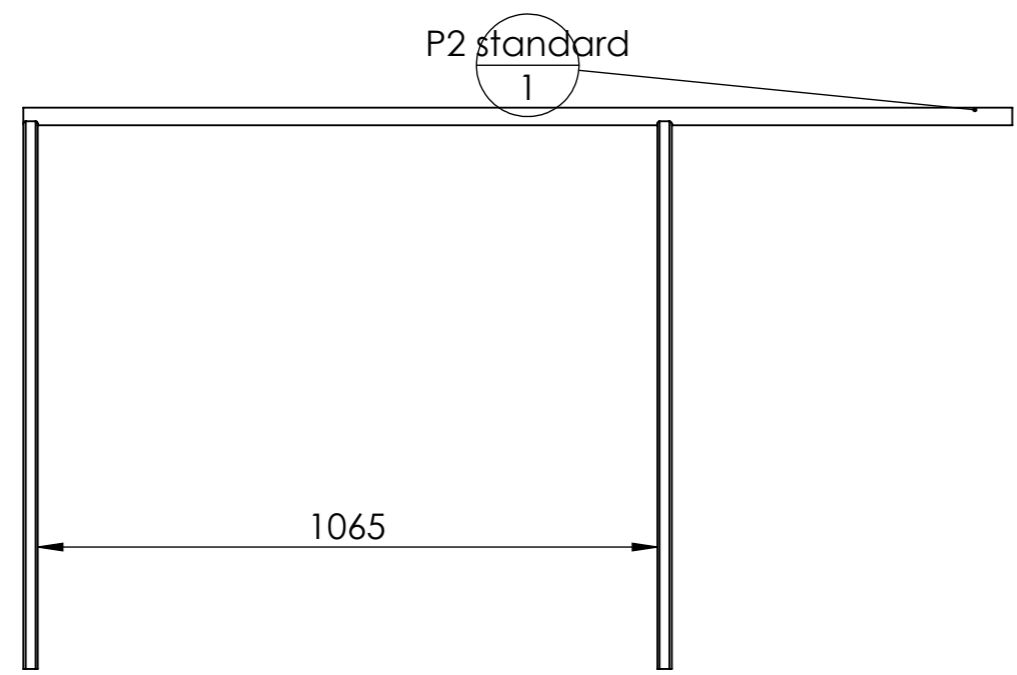

Fonds Européen Agricole pour le Développement Rural
L'Europe s'engage en France

pièce **poignée** p : 7 / 8 Qté 1

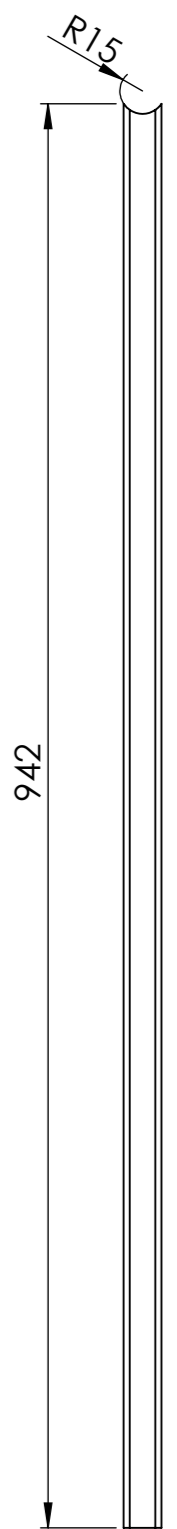

Gueule de loup



NUMERO DE PIECE	DESCRIPTION	Longueur	QTE
P1	tube carré 25 x 2	950	2
P2 standard	tube rond 30 x 2	1700	1

VERSION ETROITE

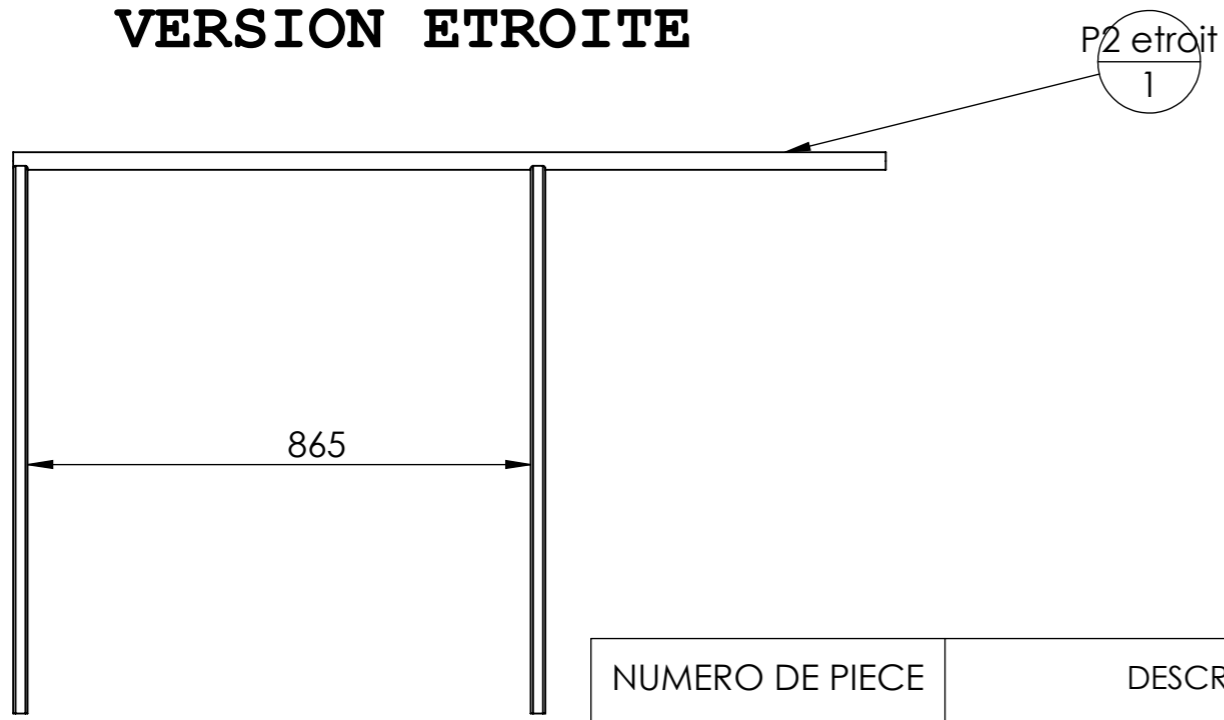

NUMERO DE PIECE	DESCRIPTION	Longueur	QTE
P1	tube carré 25 x 2	950	2
P2 étroit	tube rond 30 x 2	1500	1

Date 19/12/2016

Version 1.3

Outil **Rouleau**

Pièce	découpe lase	p : 8 / 8	Qté	1
-------	---------------------	-----------	-----	---

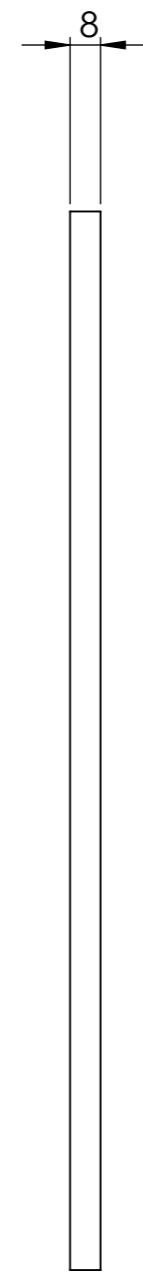
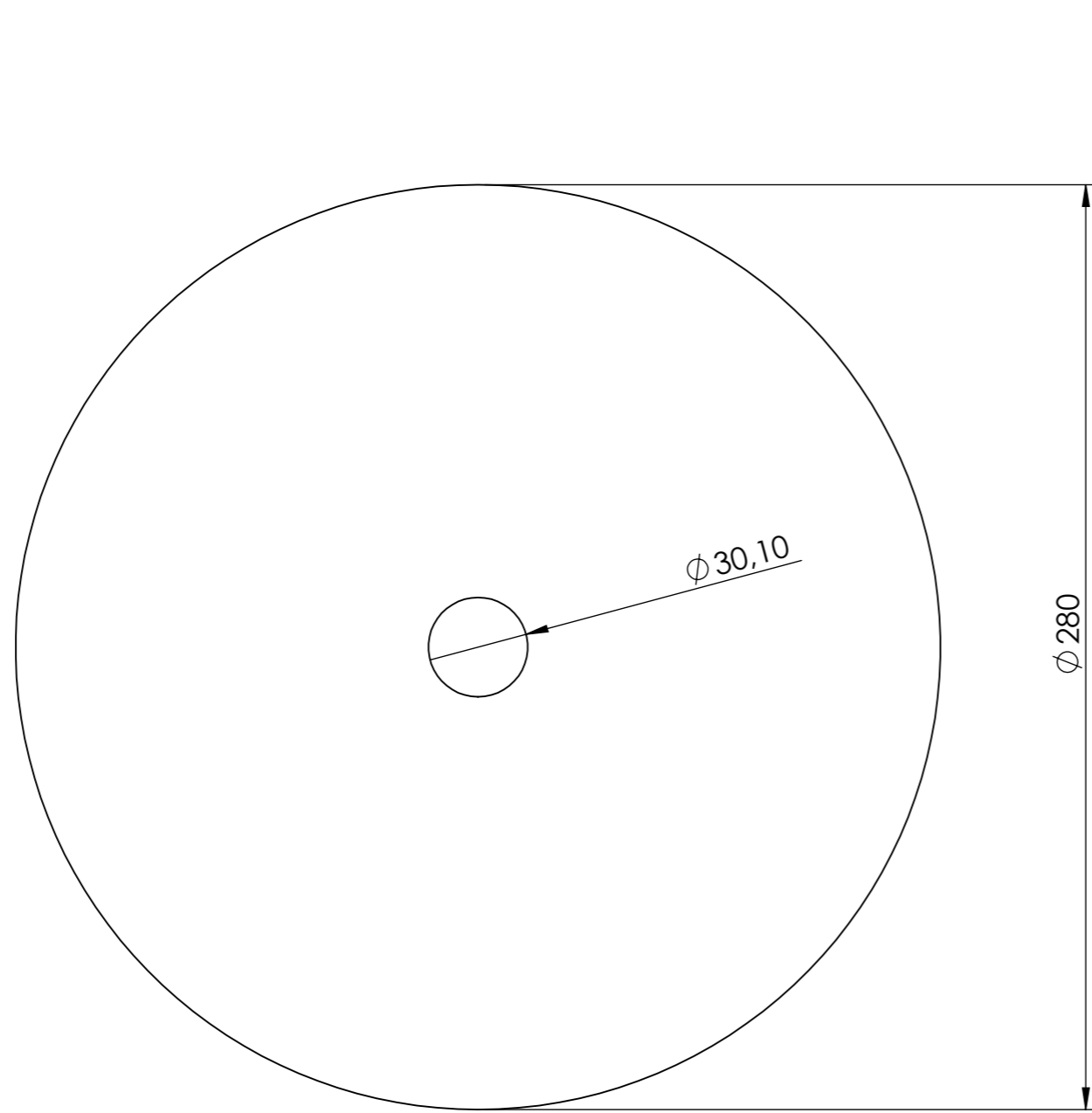

DISQUE découpe laser