

N°	Désignation	Quantité
SB	SB - Bielle parallélogramme	2
SC	SC - partie inf. parallélogramme	1
SD	SD - Bras dent latérale	2
SE	SE - support roue parallélogramme	1
SA	SA - Partie sup parallélogramme	1
SP ressort traction	Ressort traction 3,43 x 25,40 x 127	1
Rondelle	Rondelle Ø14 série ZU	8
SF	F - Dent de binage + soc 140mm	2
Ecrou	Ecrou M14 autofreiné	4
roue Ø160	Roue caoutchouc Ø160	1
Ecrou	Ecrou M16 autofreiné	1
Ecrou	Ecrou M14 brut	1
Vis Hexagonale	Vis Hexagonale M14 x 100 PF	4
Ecrou	Ecrou M14 Zingué	1
Vis Hexagonale	Vis hexagonale M14 x 30	6
Vis Hexagonale	Vis hexagonale M14 x 60	6
SF	F - Dent de binage + soc 200mm	1
Vis Hexagonale	Vis hexagonale M16 x 100	1

Outil	Parallélogramme BPO		
Date	21/06/2018	Version	1.4
Pièce	Encombrement	Qté	1

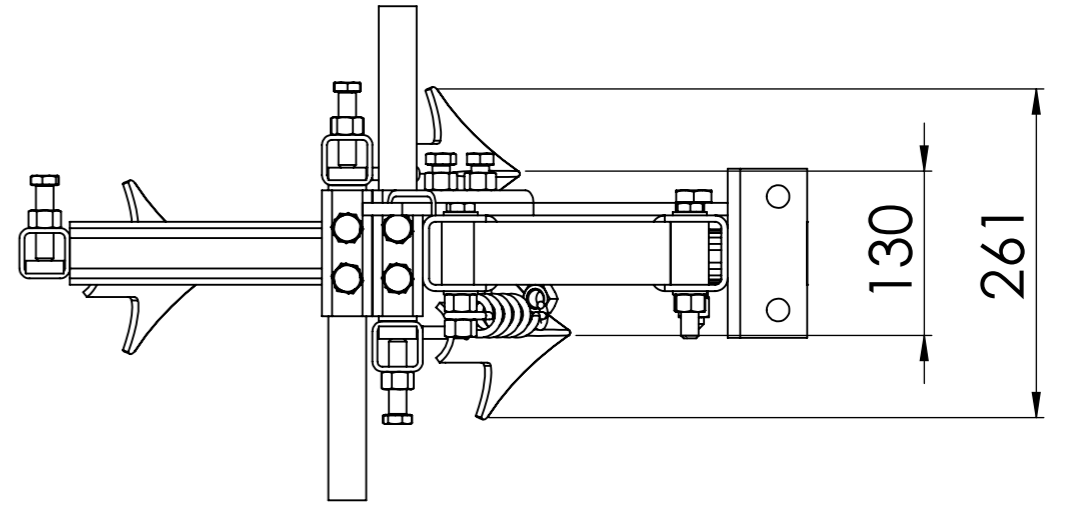

Outil	Parallélogramme BPO			
Date	21/06/2018	Version	1.4	page n° 3 / 7
Pièce	SA		Qté	1

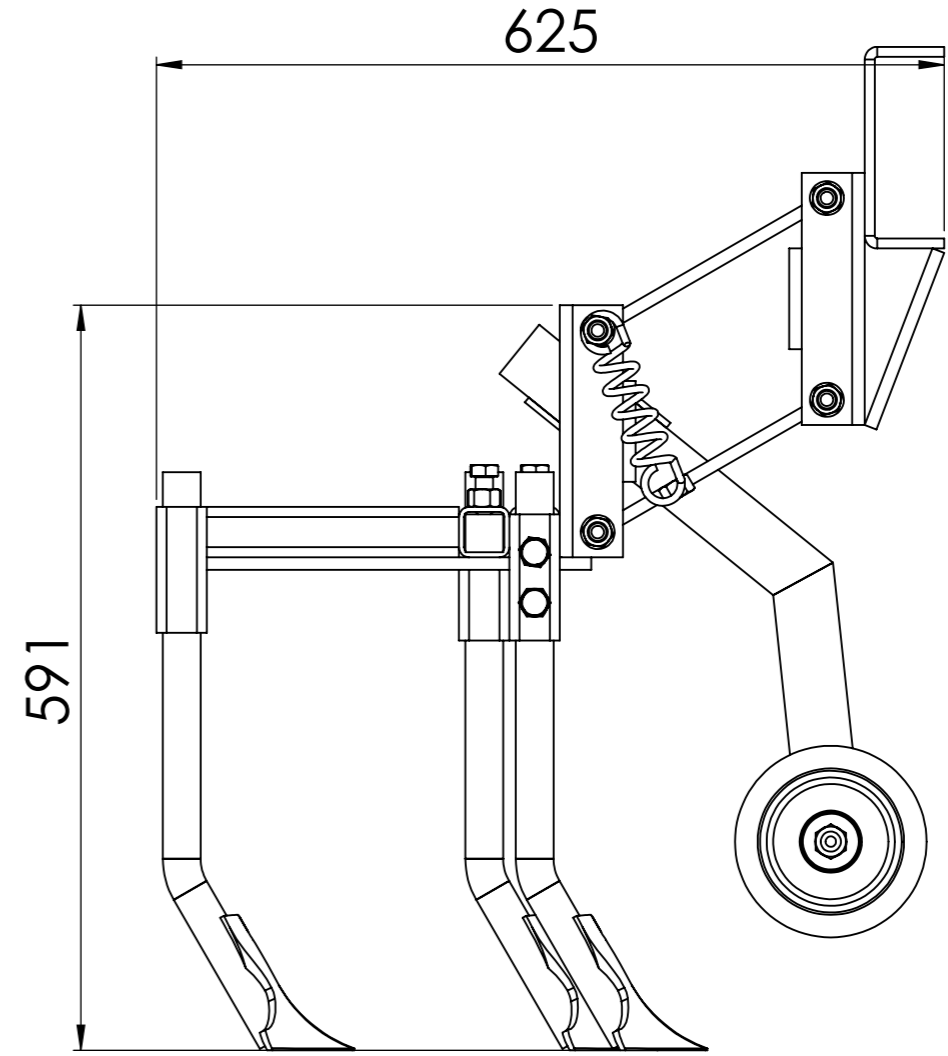
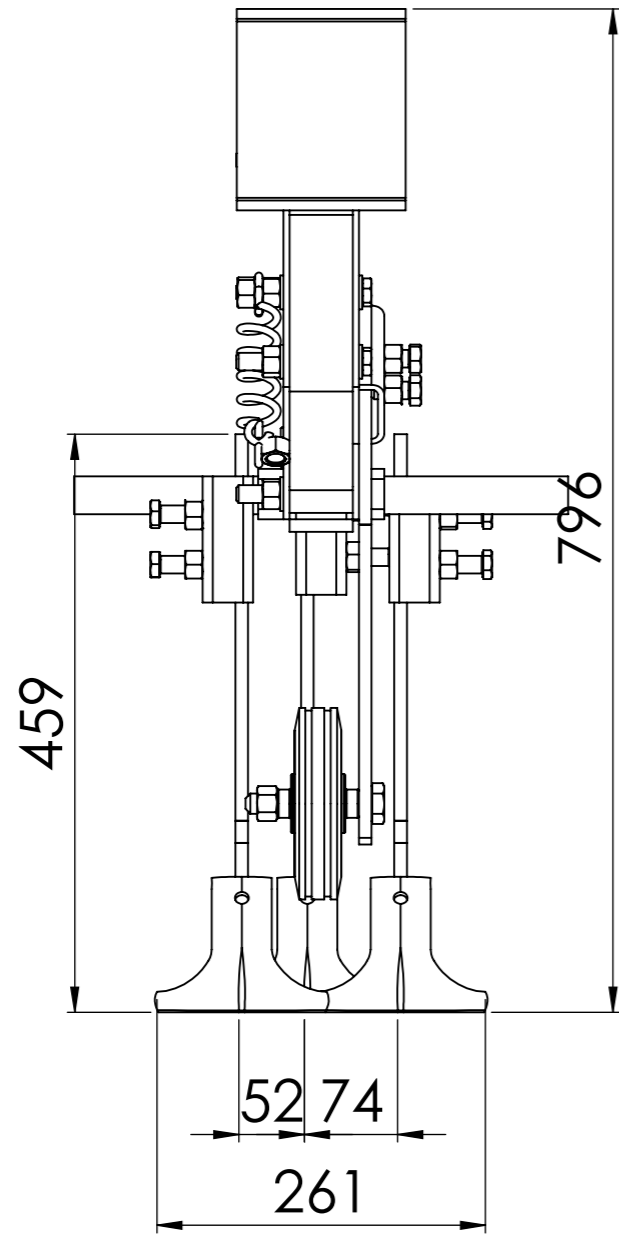
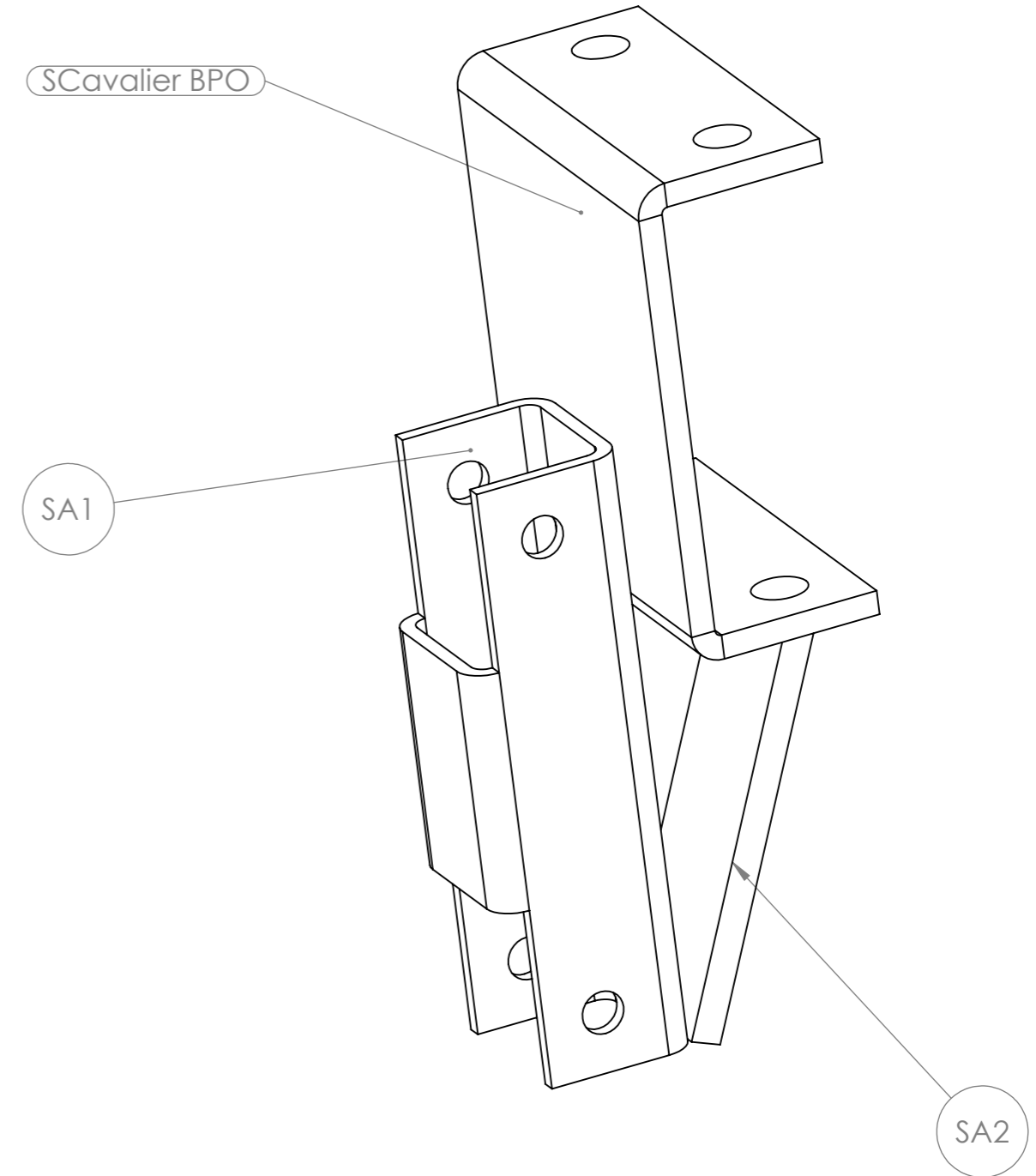
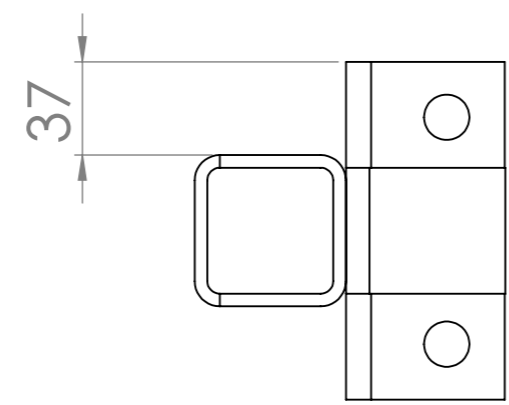
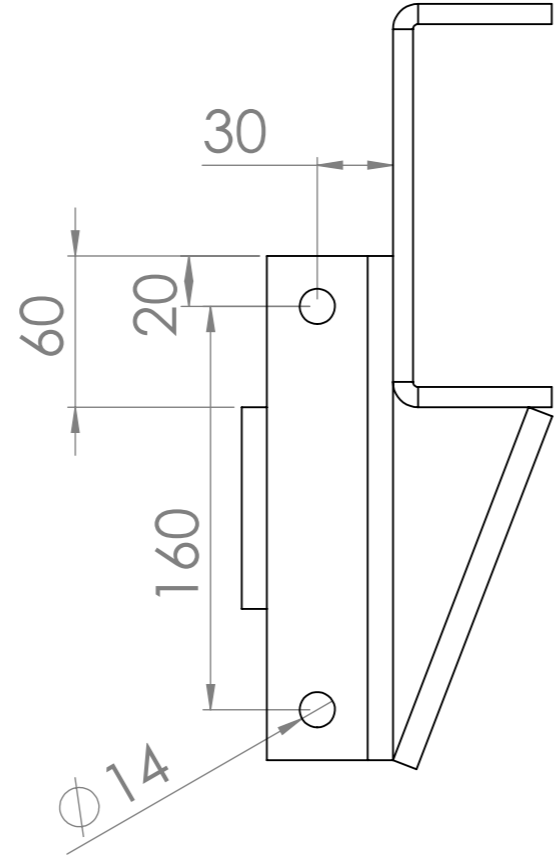
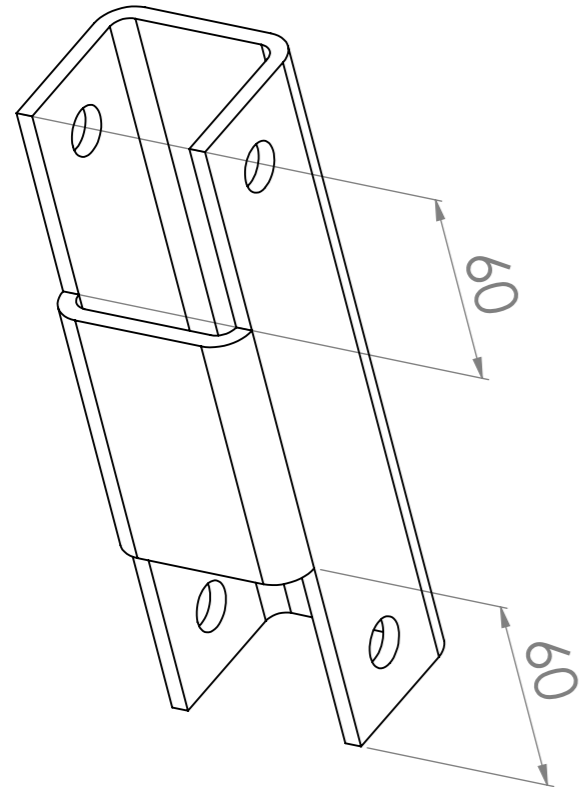

Couper une face du tube carré SA1 sur 60mm

N°	Désignation	Longueur	Qté
SA1	tube carré 60 x 5	200	1
SA2	Fer plat 50 x 10	150	1
SCavalier BPO	Cavalier BPO		1

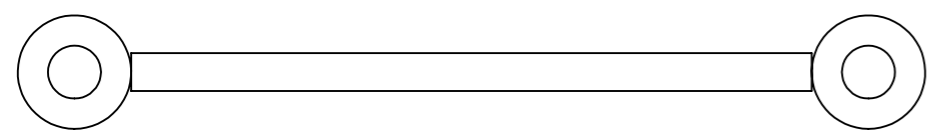
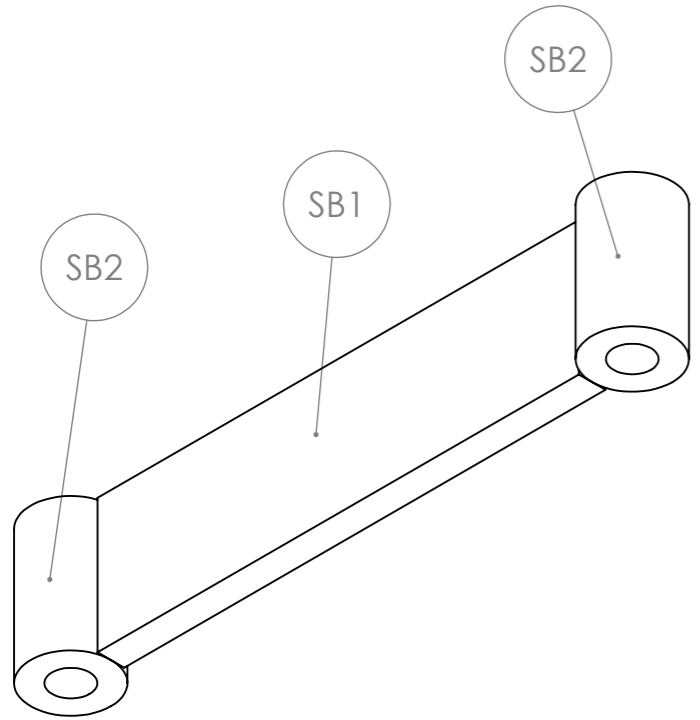

La coaxialité des tubes SB2 est primordiale

Nom	SB - Bielle parallélogramme	Qté	2
-----	-----------------------------	-----	---

N°	Désignation	Longueur	Qté
SB1	Fer plat 50 x 10	180	1
SB2	Douille tournée Øint14/Øext30/l=49mm		2

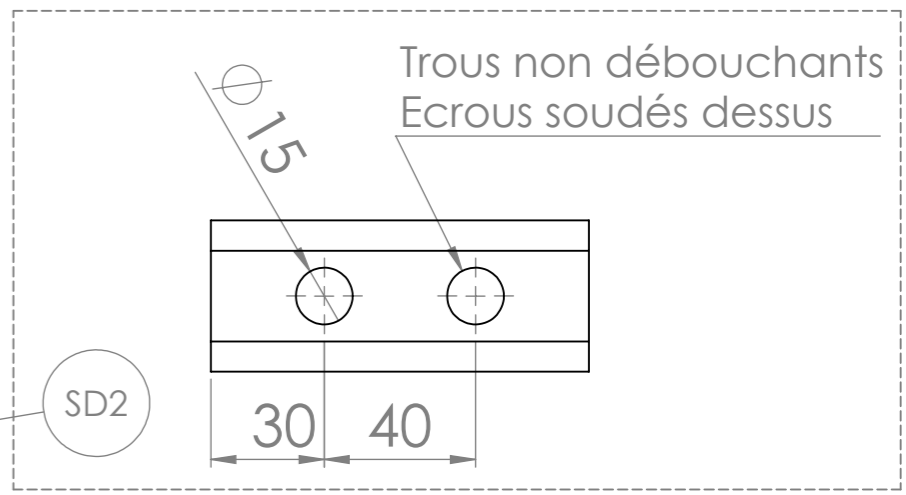
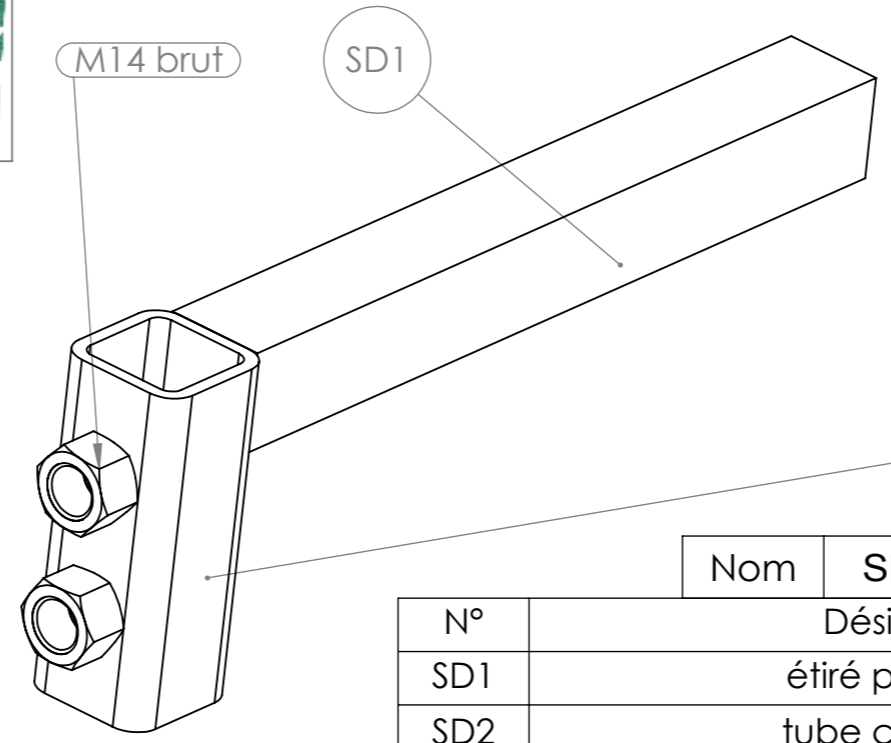

Nom	SD - Bras dent latérale	Qté	2
-----	-------------------------	-----	---

N°	Désignation	Longueur	Qté
SD1	étiré plat 30 x 30	250	1
SD2	tube carré 40 x 4	100	1
Ecrou	Ecrou M14 brut		2

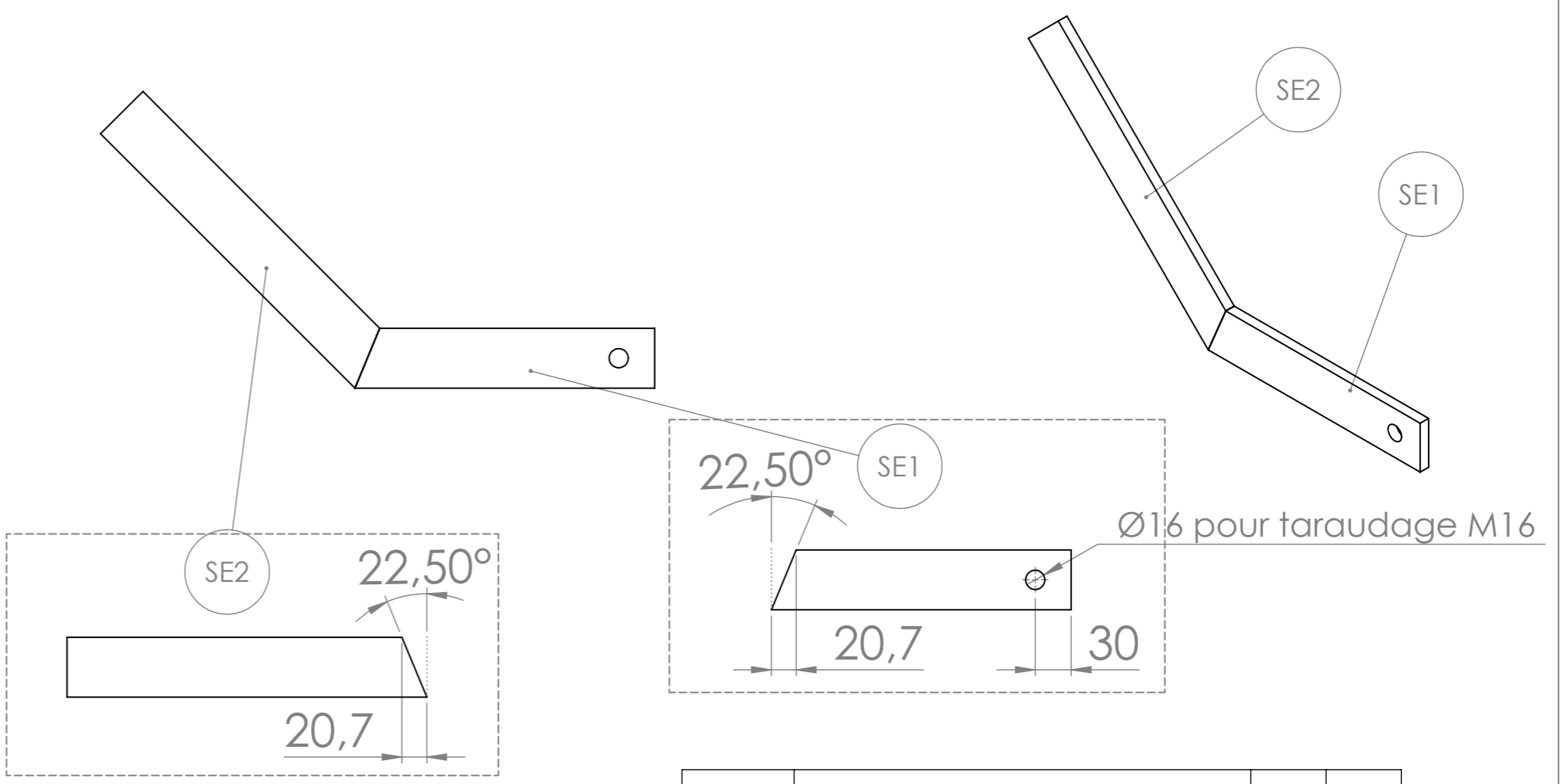

Nom	SE - Support de roue	Qté	1
-----	----------------------	-----	---

N°	Désignation	Longueur	Qté
SE1	Fer plat 50 x 10	250	1
SE2	Fer plat 50 x 10	300	1

Outil	Parallélogramme BPO				
Date	21/06/2018	Version	1.4	page n° 5 / 7	
Pièce	SC			Qté 1	



SC1 est identique à SA1

N°	Désignation	Longueur	Qté
SC1	tube carré 60 x 5	200	1
SC3	tube carré 40 x 4	100	3
SC4	tube carré 40 x 4	200	1
SC6	Fer plat 50 x 10	305	1
SC5	tube carré 60 x 5	100	1
Ecrou	Ecrou M14 brut		8

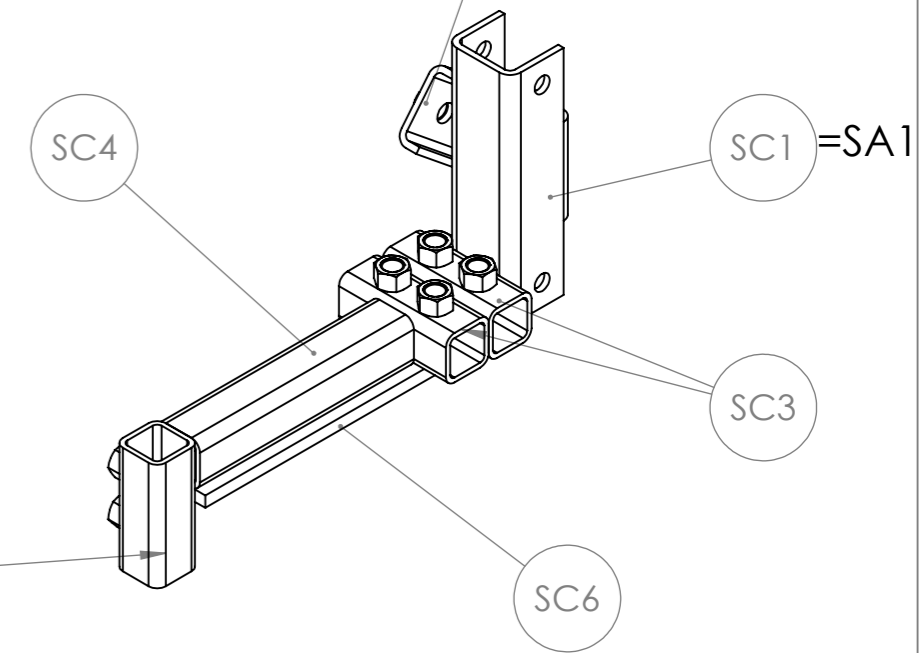
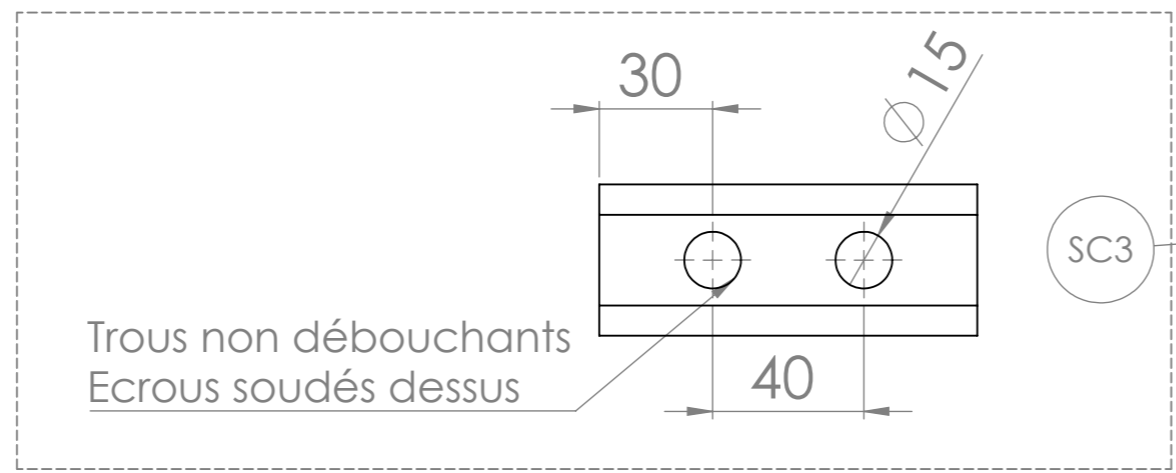
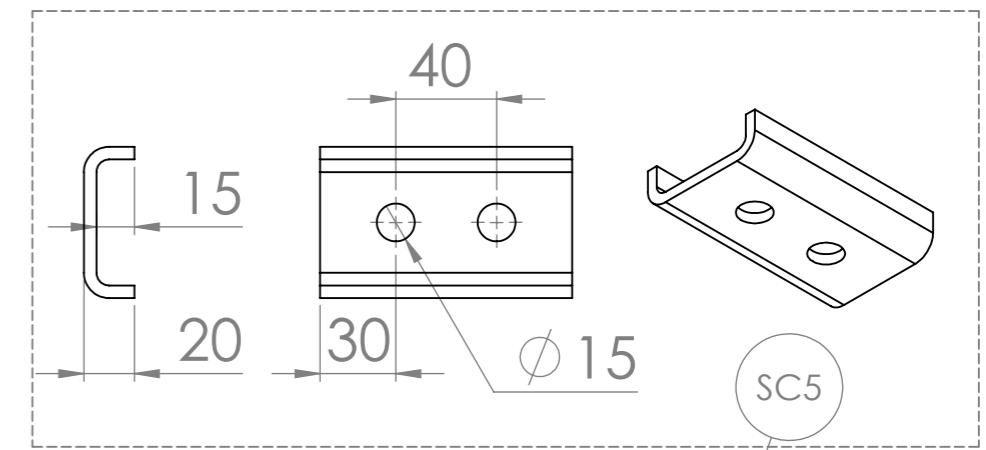
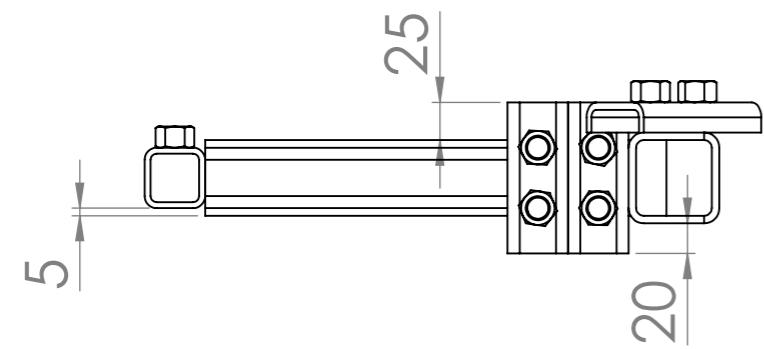
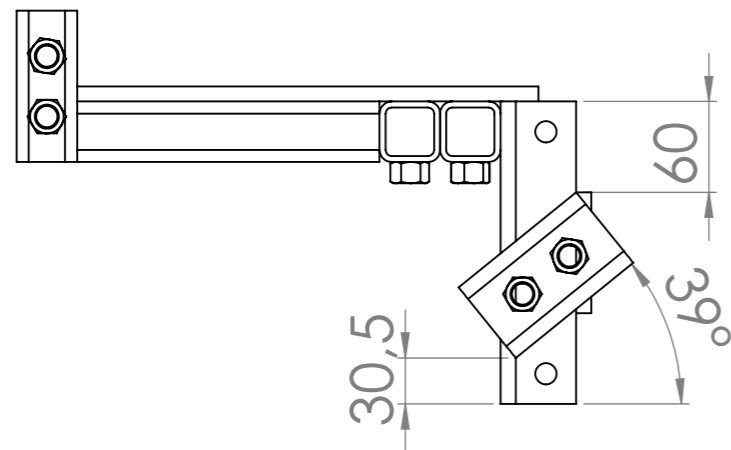

Outil	Parallélogramme BPO		
Date	21/06/2018	Version	1.4 page n° 6 / 7
Pièce	Montage parallélogramme	Qté	1



Monter les bras B dans B1 et C1 avec des vis M14x100

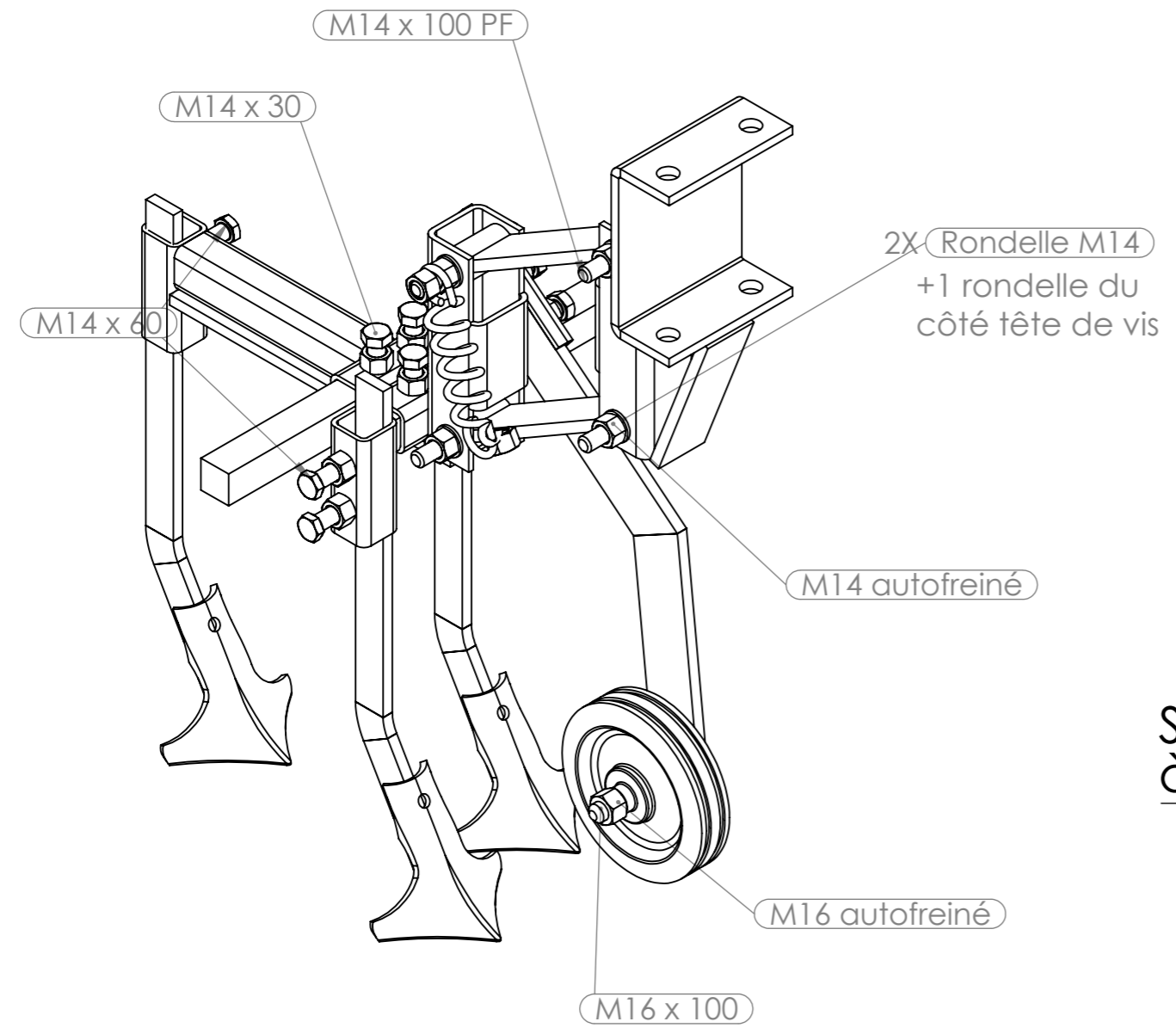

Coincer ce côté du ressort dans la vis M14x100

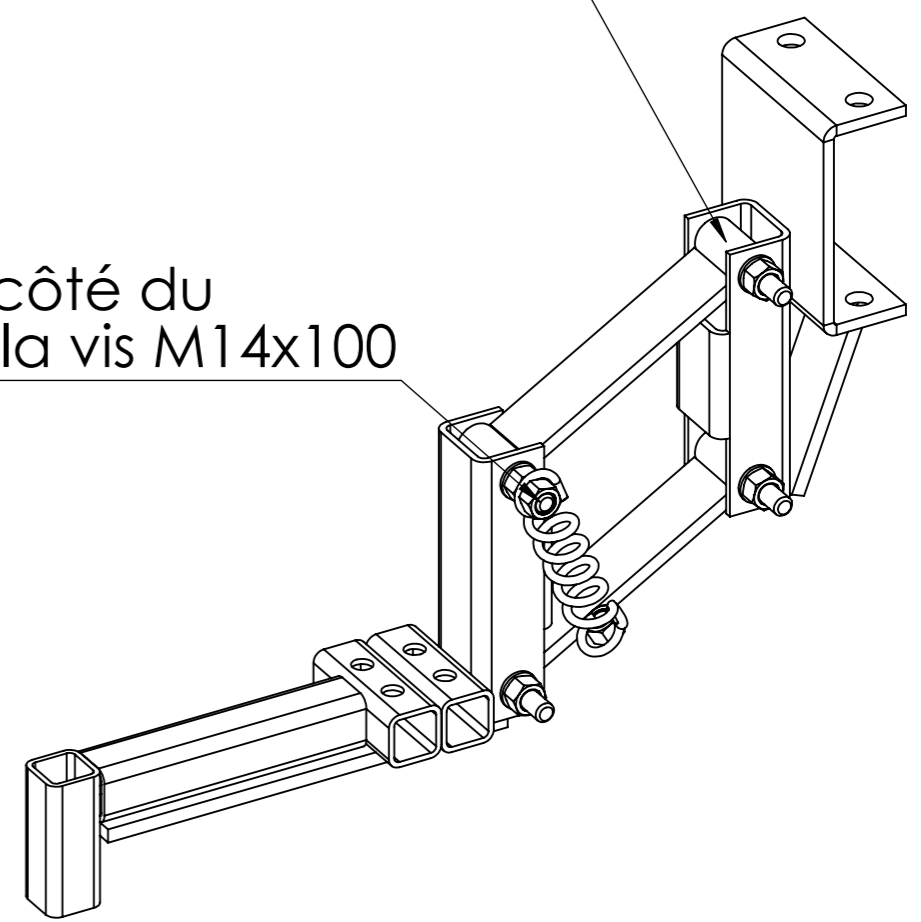

Souder l'autre extrémité du ressort à un écrou M14 soudé sur le bras B

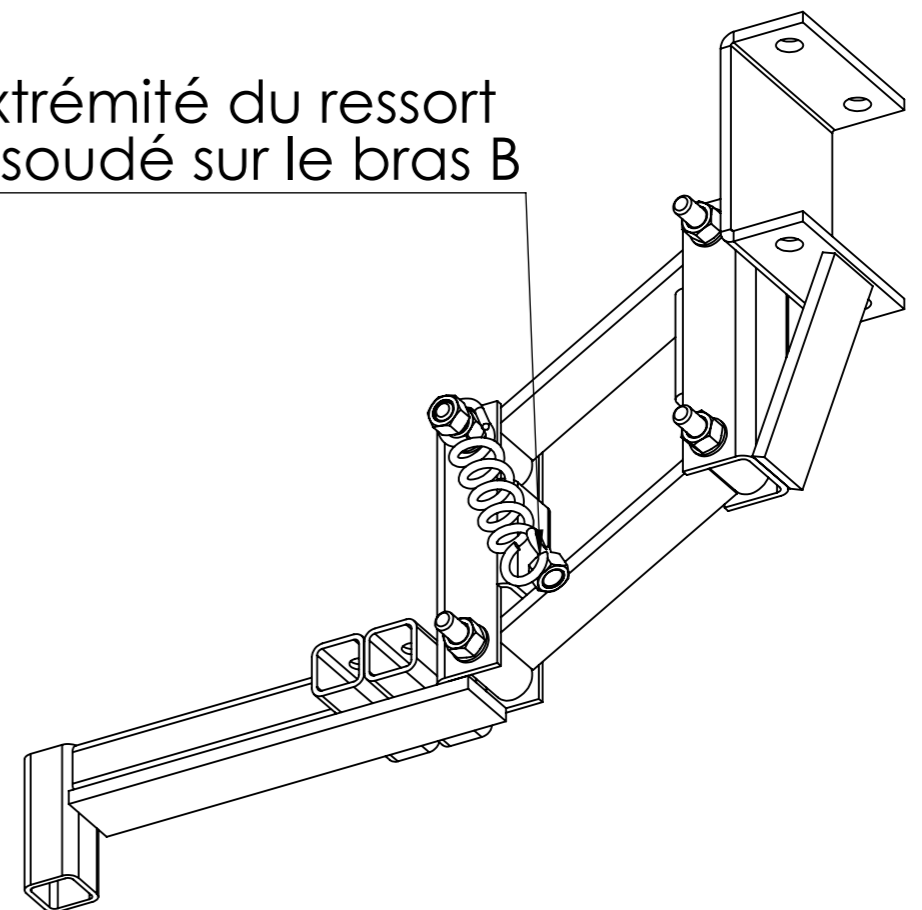

Outil	Parallélogramme BPO		
Date	21/06/2018	Version	1.4
		page n°	7 / 7
Pièce	Nomenclature générale	Qté	1

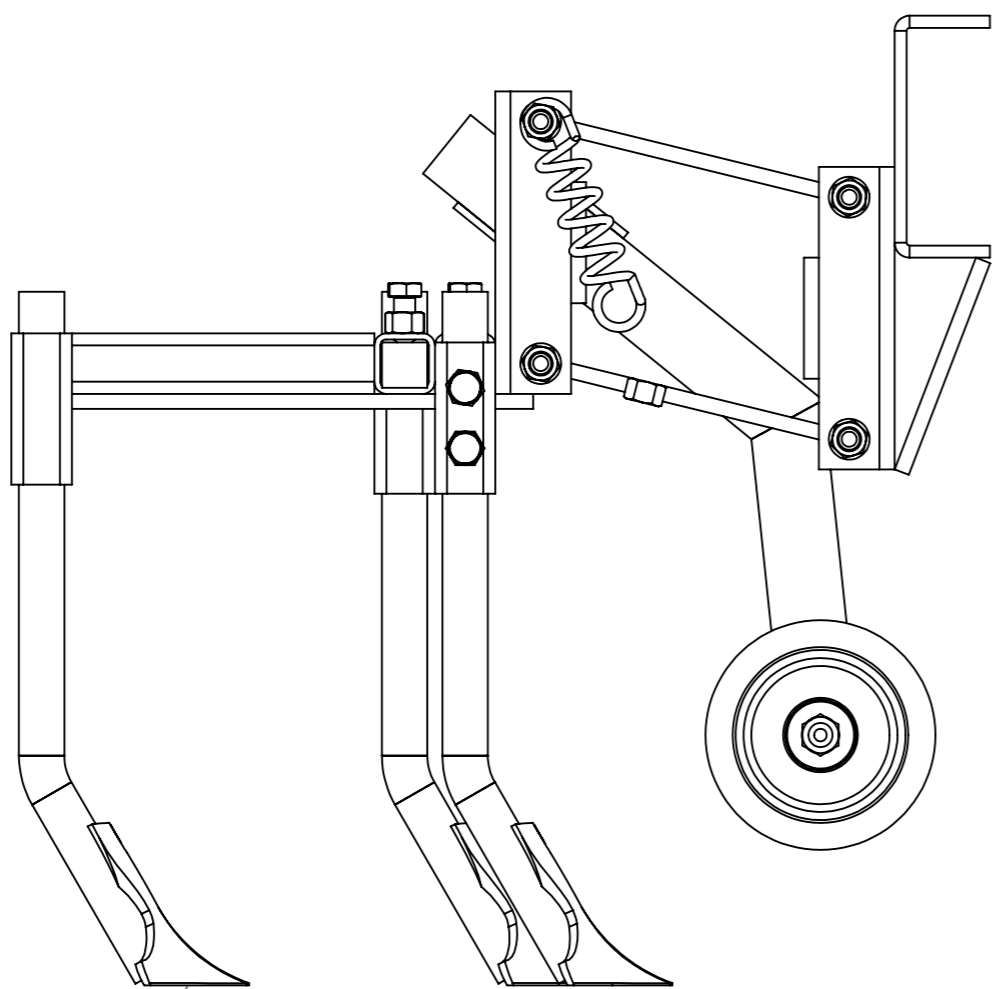

Les socs sont soudés aux dents

N°	Désignation	Longueur	Qté
SCavalier BPO	Cavalier BPO		1
Erou	Erou M14 autofreiné		4
Erou	Erou M14 brut		13
SB1	Fer plat 50 x 10	180	2
SC6	Fer plat 50 x 10	305	1
SA2	Fer plat 50 x 10	150	1
SE1	Fer plat 50 x 10	250	1
SE2	Fer plat 50 x 10	300	1
roue Ø160	Roue caoutchouc Ø160		1
SF1	Tige 30x10 pour dent bineuse		3
Rondelle	Rondelle Ø14 série ZU		8
SP ressort traction	Ressort traction 3,43 x 25,40 x 127		1
SC3	tube carré 40 x 4	100	3
SC4	tube carré 40 x 4	200	1
SD2	tube carré 40 x 4	100	2
SC1	tube carré 60 x 5	200	1
SC5	tube carré 60 x 5	100	1
SA1	tube carré 60 x 5	200	1
SB2	Douille tournée Øint14/Øext30/l=49mm		4
SD1	étiré plat 30 x 30	250	2
Soc patte d'oie	Soc patte d'oie vibroplanche		3
Erou	Erou M16 autofreiné		1
Vis Hexagonale	Vis Hexagonale M14 x 100 PF		4
Erou	Erou M14 Zingué		1
Vis Hexagonale	Vis hexagonale M14 x 30		6
Vis Hexagonale	Vis hexagonale M14 x 60		6
Vis Hexagonale	Vis hexagonale M16 x 100		1