

Outil	Servante à rouleaux		
Date	02/11/2016	Version	1.0
Pièce	Vue d'ensemble		Qté 1

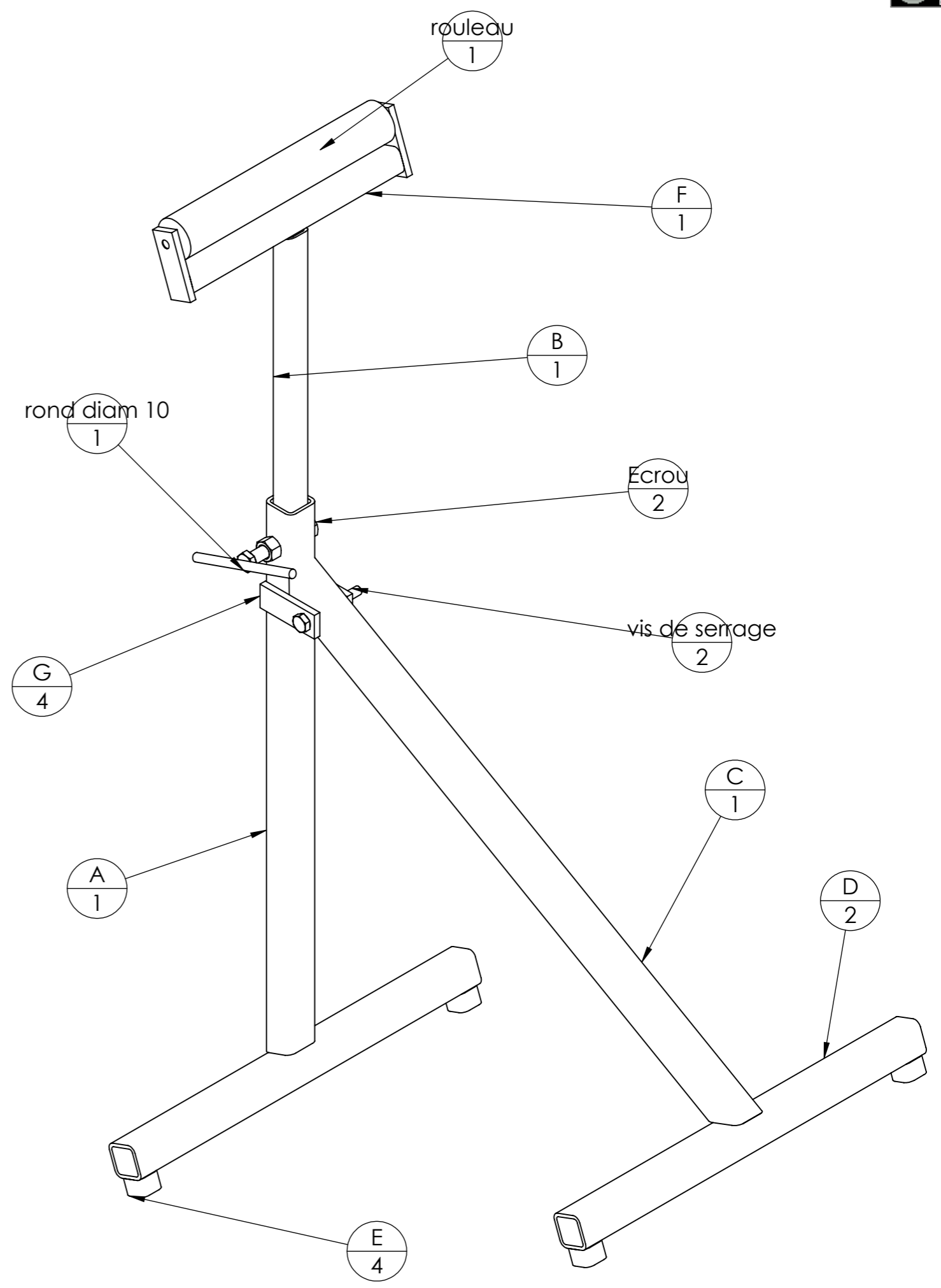

N°	Désignation	Longueur	Qté
A	tube carré 40 x 4	700	1
C	tube carré 40 x 4	760	1
D	tube carré 40 x 4	500	2
B	tube carré 30 x 4	700	1
E	tube carré 30 x 4	20	4
rouleau			1
F	tube carré 30 x 4	310	1
G	Fer plat 30 x 8	80	4
Ecrou	Ecrou M14 Zingué		2
vis de serrage	Vis hexagonale M10 x 80		1
vis de serrage	Vis hexagonale M14 x 40		1
rond diam 10	rond diam 10	150	1



Outil	Servante à rouleaux		
Date	02/11/2016	Version	1.0 page n° 2 / 3
Pièce	Assemblage bas	Qté	1

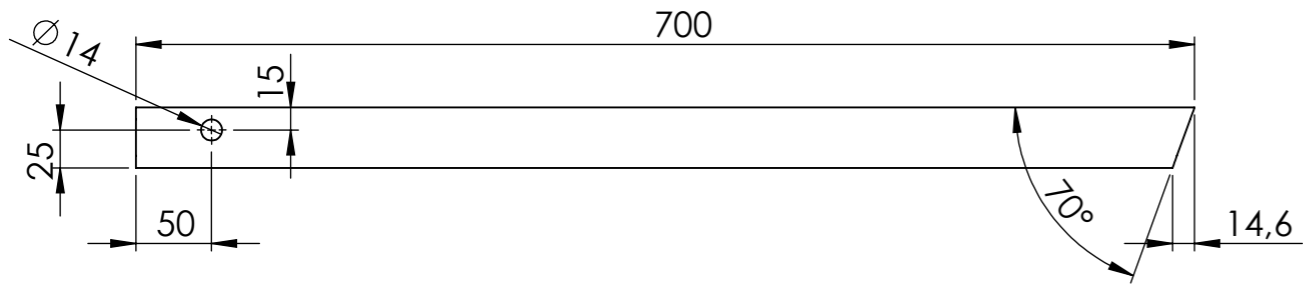

N°	Désignation	Longueur	Qté
A	tube carré 40 x 4	700	1

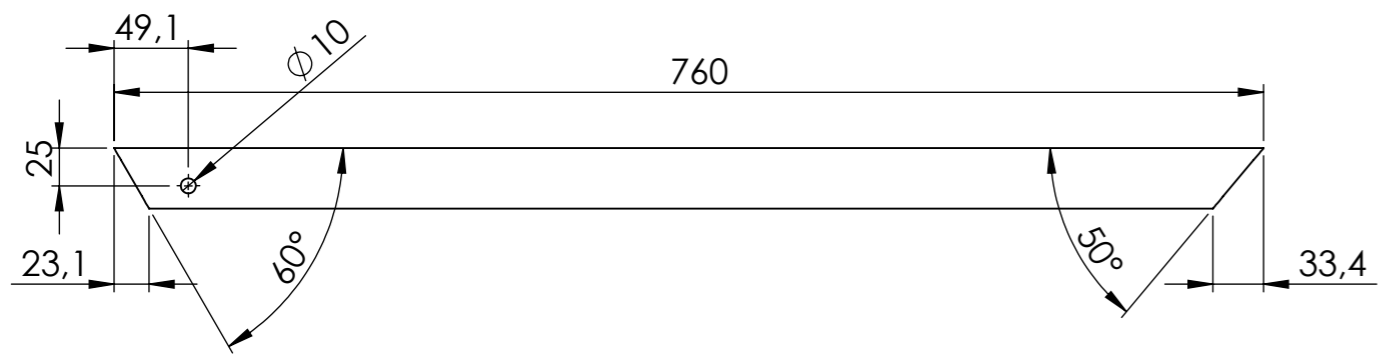

N°	Désignation	Longueur	Qté
C	tube carré 40 x 4	760	1

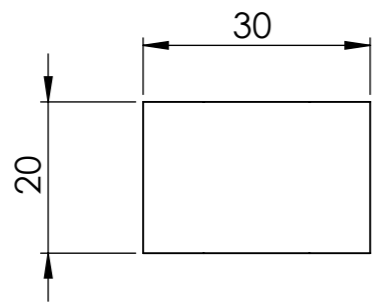

N°	Désignation	Longueur	Qté
E	tube carré 30 x 4	20	4

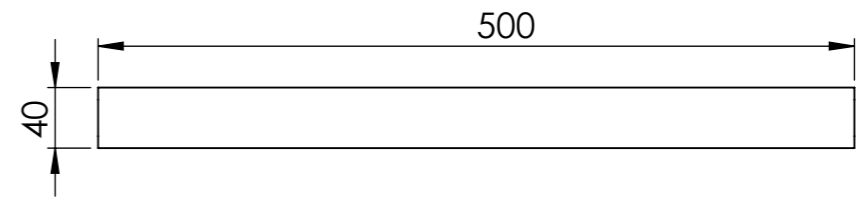
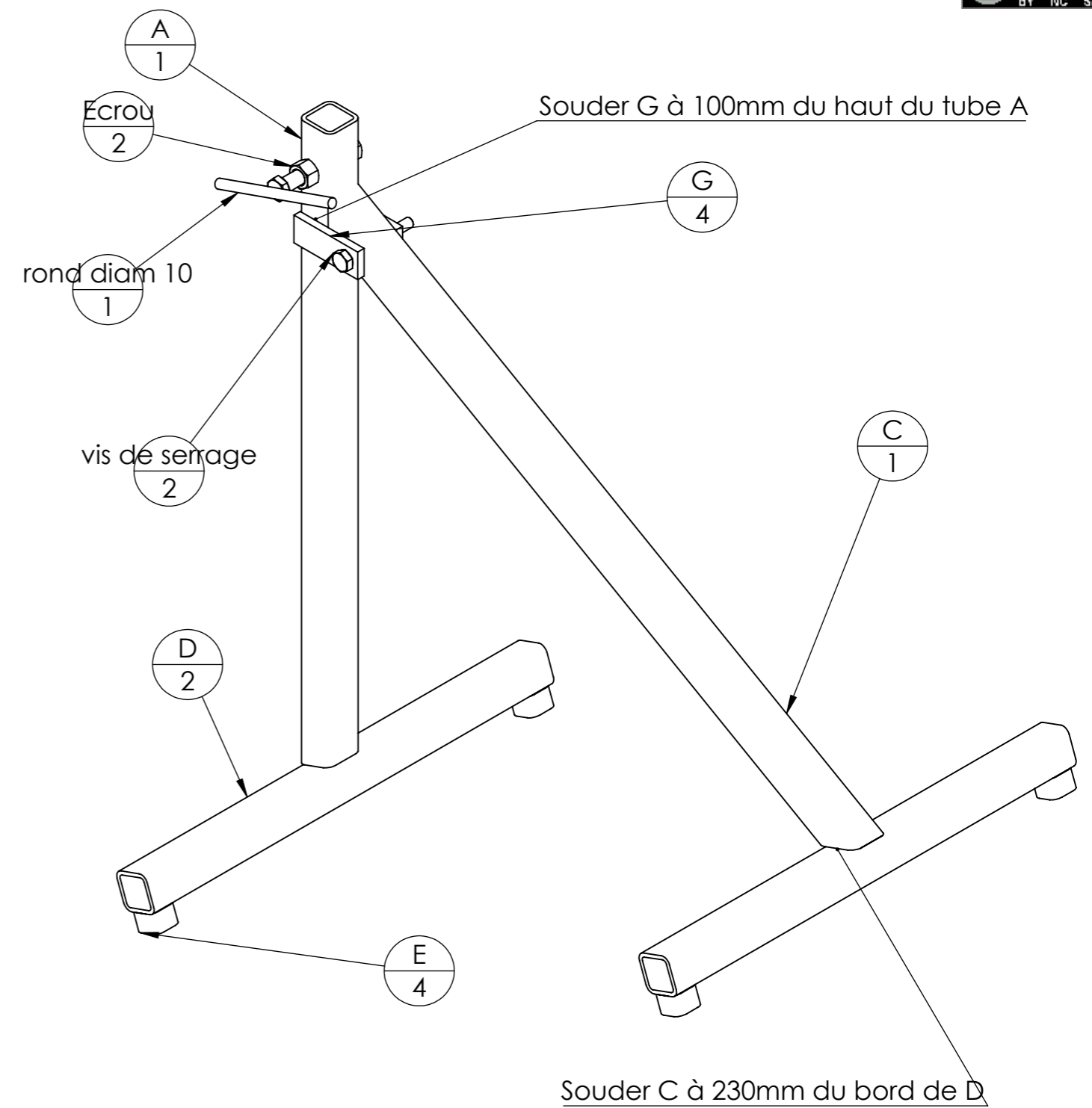

N°	Désignation	Longueur	Qté
D	tube carré 40 x 4	500	2

Outil	Servante à rouleaux		
Date	02/11/2016	Version	1.0
		page n°	3 / 3
Pièce	Assemblage haut	Qté	1

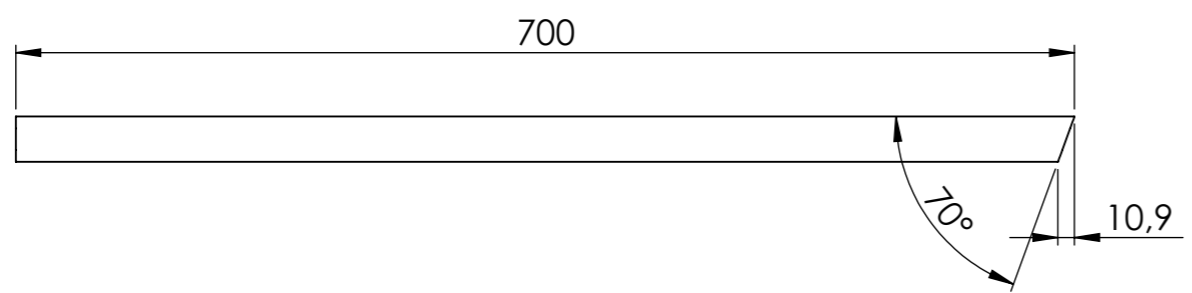

N°	Désignation	Longueur	Qté
B	tube carré 30 x 4	700	1

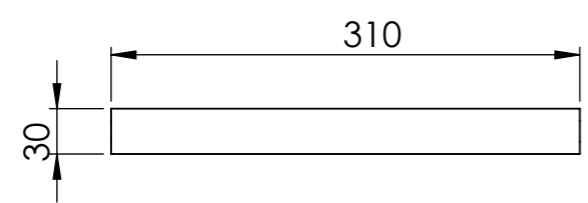

N°	Désignation	Longueur	Qté
F	tube carré 30 x 4	310	1

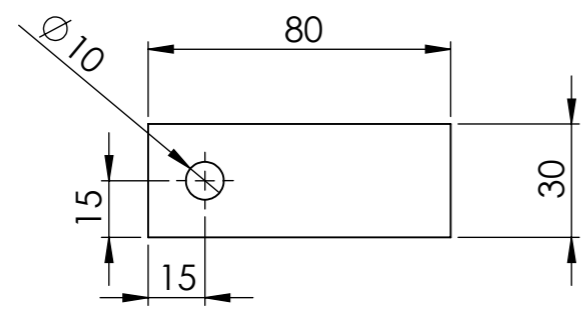

N°	Désignation	Longueur	Qté
G	Fer plat 30 x 8	80	2

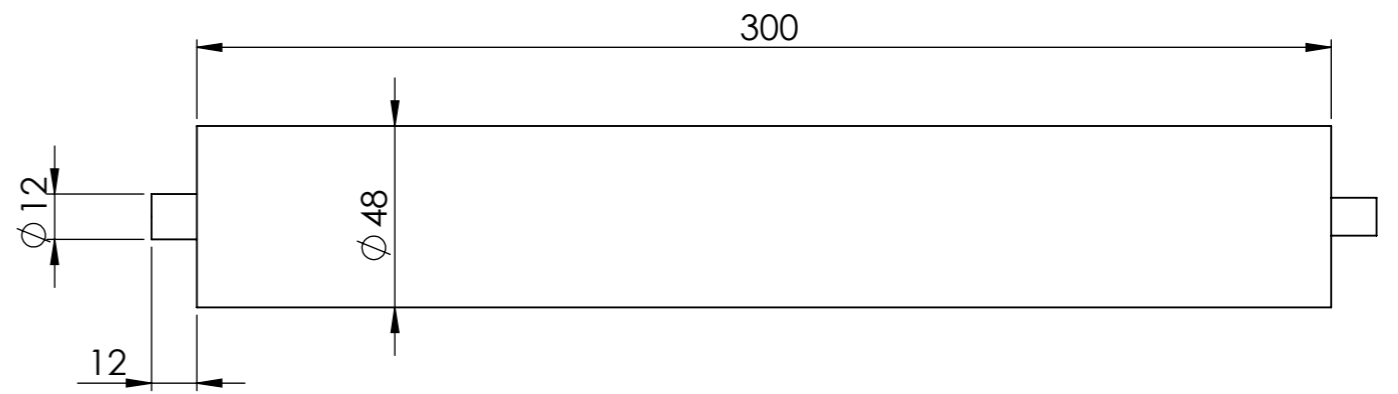
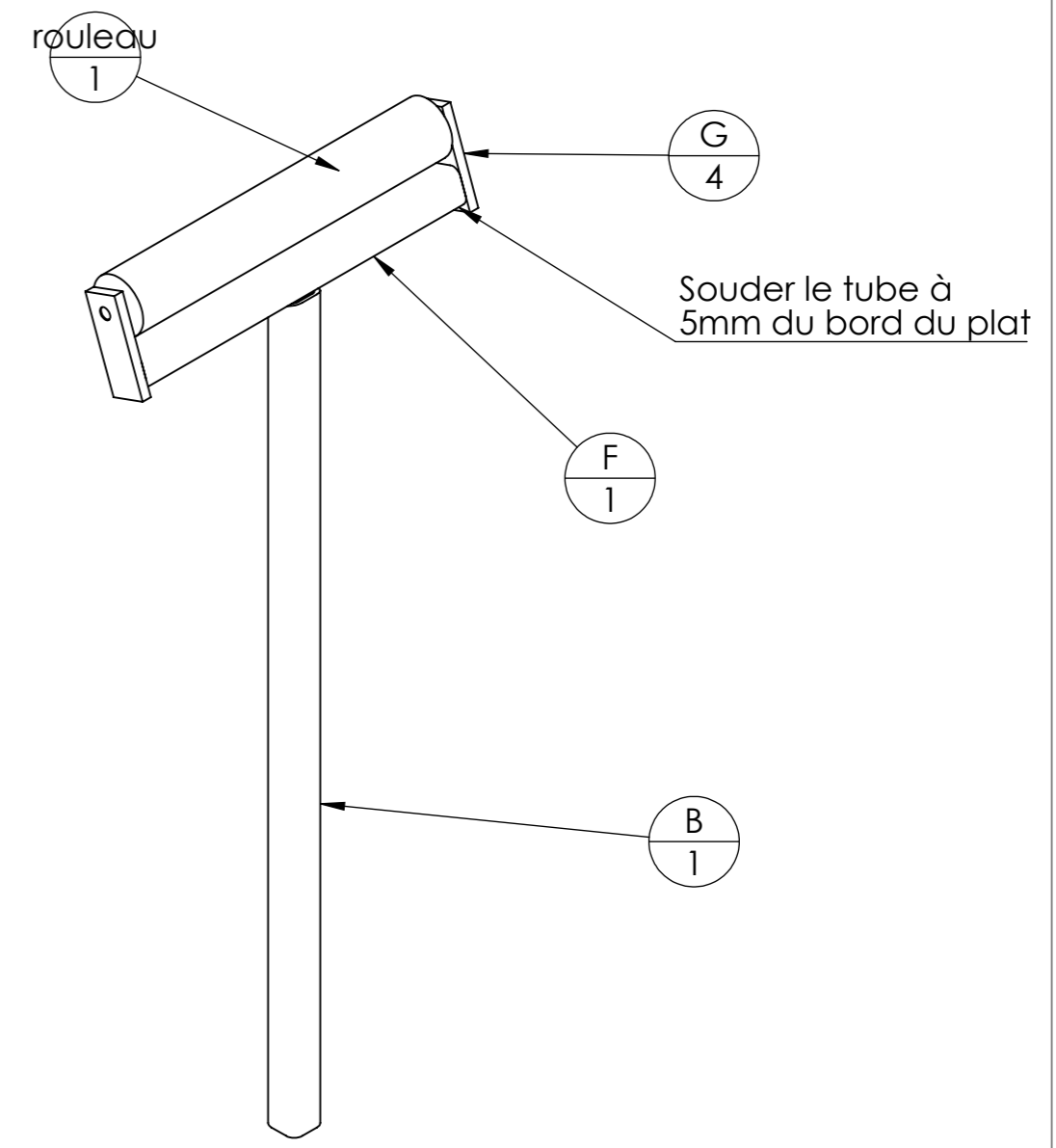

N°	Désignation	Longueur	Qté
rouleau			1